



Non - Automatic Bilge Pumps 01 Series

Features & Benefits

- Pump and switch are stand alone products
- Compact, efficient, long life motors
- New mercury free float switches
- Size: 350, 500, 750, 1100, 1500, 2000, 3000, 3500 gph in 12 and 24 volt versions
- Easy clean snap-lock strainer bases
- Anti-Airlock protection
- Exclusive moisture tight seals
- Completely submersible
- Marine grade blocked wiring
- Silent and vibrationless operation

Typical Applications

- Marine
- RV & Campers
- Industrial

PUMP

- Liquid Temperature**
110°F (43°C) Max.
- Priming Capabilities**
Not needed flooded suction
- Power**
3.5 amps max current draw
- Max Pressure**
Not needed

MOTOR

- Type**
Compact, efficient, long life motor
- Leads**
18 AWG, 1 m long Leads
- Temperature Limits**
110°F (43°C) Max.
- Duty Cycle**
Intermittent
- Voltage**
12v/24v

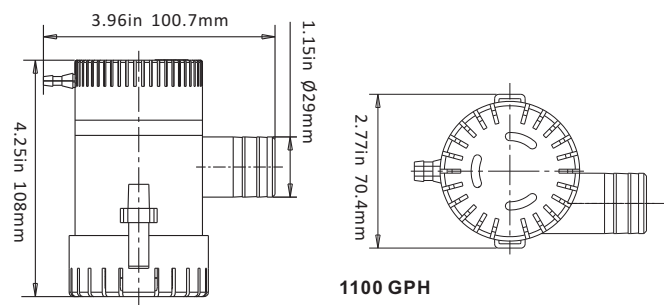
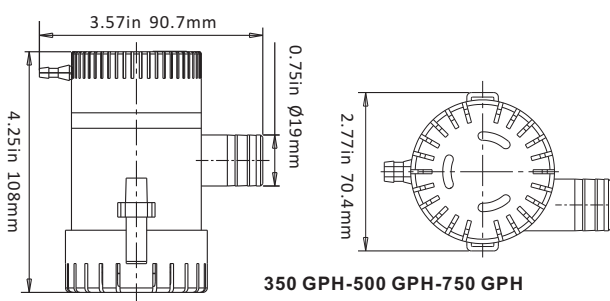

STANDARD PUMP CONFIGURATIONS

Model	Flow rate	Volts	Current	Head	Wire lead	Outlet Dia	N.W/G.W
SFBP1-G350-01	350 GPH	12 V	1.8 A	3 m	1 m	19 mm/3/4"	0.33/0.40 kg
SFBP1-G500-01	500 GPH	12 V	2.2 A	3 m	1 m	19 mm/3/4"	0.33/0.40 kg
SFBP2-G500-01	500 GPH	24 V	1.2 A	3 m	1 m	19 mm/3/4"	0.33/0.40 kg
SFBP1-G750-01	750 GPH	12 V	2.5 A	3 m	1 m	19 mm/3/4"	0.33/0.40 kg
SFBP2-G750-01	750 GPH	24 V	1.5 A	3 m	1 m	19 mm/3/4"	0.33/0.40 kg
SFBP1-G1100-01	1100 GPH	12 V	3.5 A	4 m	1 m	29 mm/1-1/8"	0.38/0.44 kg
SFBP2-G1100-01	1100 GPH	24 V	1.5 A	4 m	1 m	29 mm/1-1/8"	0.38/0.44 kg