

OPERATION  
AND  
MAINTENANCE  
MANUAL

**MARINER**

75 • 90 HP MODELS

## READ THIS MANUAL THOROUGHLY

If you don't understand any portion, contact your dealer for a demonstration of actual starting and operating procedures.

### NOTICE

Throughout this publication, and on your outboard, **DANGER, WARNINGS** and **CAUTIONS**, accompanied by the International **HAZARD** Symbol , may be used to alert the installer/user to special instructions concerning a particular service or operation that may be hazardous if performed incorrectly or carelessly. **OBSERVE THEM CAREFULLY.**

These "Safety Alerts" alone cannot eliminate the hazards that they signal. Strict compliance with these special instructions while performing the service, plus "common sense" operation, are major accident prevention measures.



### DANGER

**DANGER** - Immediate hazards which **WILL** result in severe personal injury or death.



### WARNING

**WARNING** - Hazards or unsafe practices which **COULD** result in severe personal injury or death.



### CAUTION

**CAUTION** - Hazards or unsafe practices which could result in minor personal injury or product or property damage.

**IMPORTANT** - Indicates information or instructions that are necessary for proper operation and/or maintenance.



### WARNING

The operator (driver) is responsible for the correct and safe operation of the boat, the equipment aboard and the safety of all occupants aboard. We strongly recommend that the operator read this Operation

and Maintenance Manual and thoroughly understand the operational instructions for the outboard and all related accessories before the boat is used.



### WARNING

The following advantages and disadvantages of a **LANYARD STOP SWITCH** should be considered before electing to use, or not to use, such a switch.

**ADVANTAGES:** The purpose of a **LANYARD STOP SWITCH** is to stop the engine when the operator leaves control station, either accidentally by falling into the boat, or by falling or being ejected overboard. This is most likely in certain types of boats such as low-sided bass boats, high performance boats and light, sensitive handling, fishing boats operated by hand-tiller. It is also likely as a result of poor operating practices such as sitting on the back of the seat at planing speeds, standing at planing speeds, operating at high speeds in shallow or obstacle-infested waters, drinking and driving, or daring, high speed boat maneuvers.

**DISADVANTAGES:** Inadvertent activation of the switch is also a possibility. This could cause any or all of the following potentially hazardous situations:

- Loss of balance and falling forward of unstable boat passengers - a particular concern in bow rider type boats.
- Loss of power and directional control in heavy seas, strong current or high winds.
- Loss of control when docking.

As we cannot possibly know of and advise the boating public of ALL conceivable boat/motor types and/or poor operating practices, the final decision of whether or not to use a LANYARD STOP SWITCH rests with you, the owner/driver.

We strongly recommend that other occupants be instructed on proper starting and operating procedures so they will be prepared should they be required to operate the outboard and boat in an emergency.



**WARNING**

It is difficult for a person standing or floating in the water to move clear if they see a powerboat heading toward them, even at slow speed. Shift the unit to neutral and shut off engine when your boat is near people in the water.

**SERIOUS INJURY IS LIKELY IF A PERSON IN THE WATER IS STRUCK BY A MOVING BOAT, GEAR HOUSING, PRO-**

**PELLER, OR ACCESSORY RIGIDLY ATTACHED TO YOUR BOAT OR OUTBOARD.**



**WARNING**

The use of accessories not manufactured or sold by Mercury Marine is not recommended for use with your outboard. If your outboard or outboard operating system is equipped with an accessory not manufactured by Mercury Marine, be sure to read the Operation and Maintenance Manual for that accessory before operation. If you haven't been supplied with such a manual, contact your dealer or the manufacturer of the accessory to secure the applicable manual.



**WARNING**

**USE CARE** when transporting fuel container, whether in a boat or car. **DO NOT** fill fuel container to maximum capacity. Gasoline will expand considerably as it warms up and can build up pressure in the fuel container. This can cause fuel leakage and a potential fire hazard.

# TABLE OF CONTENTS

Specifications .....	5
Motor Installation.....	7
Propellers.....	11
Conditions Affecting Operation.....	12
Fuel Mixture and Fuel/Oil Recommendations .....	13
Outboard Motor Controls	
Tiller Handle Models.....	17
Operation - Tiller Handle Models .....	17
Quicksilver Side Mount Remote Control Components .....	23
Operation - Models with Remote Control .....	23
Emergency Operation .....	27
Power Trim .....	28
Lubrication/Maintenance Guide .....	31
Cowl Removal and Installation.....	32
Gear Housing Lubrication .....	33
Flushing Motor Cooling System .....	35
Ignition Maintenance .....	36
Carburetor Adjustment .....	37
Cleaning Fuel Filters.....	39
Inspection and Maintenance .....	40

The description and specifications contained herein were in effect at the time this guide was approved for printing. Mercury Marine, whose policy is one of continuous improvement, reserves the right to discontinue models at any time, to change specifications, designs, methods or procedures without notice and without incurring obligation.

Mercury Marine, Fond du Lac, Wisconsin U.S.A.

Litho in U.S.A.

©1990, Brunswick Corporation

The following are registered trademarks of Brunswick Corporation: Auto-blend, Jet-Prop, Mariner, Merc, MerCathode, MerCruiser, Mercury, Mercury Marine, Quicksilver, Ride-Guide, and Thruster.

## OUTBOARD SERIAL NUMBER LOCATION

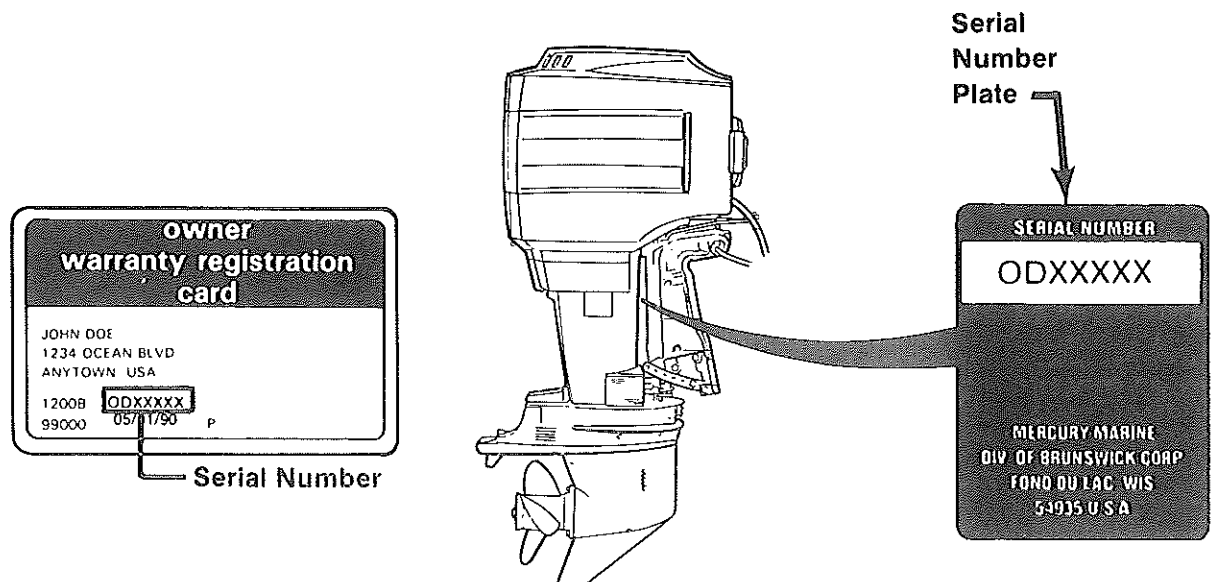

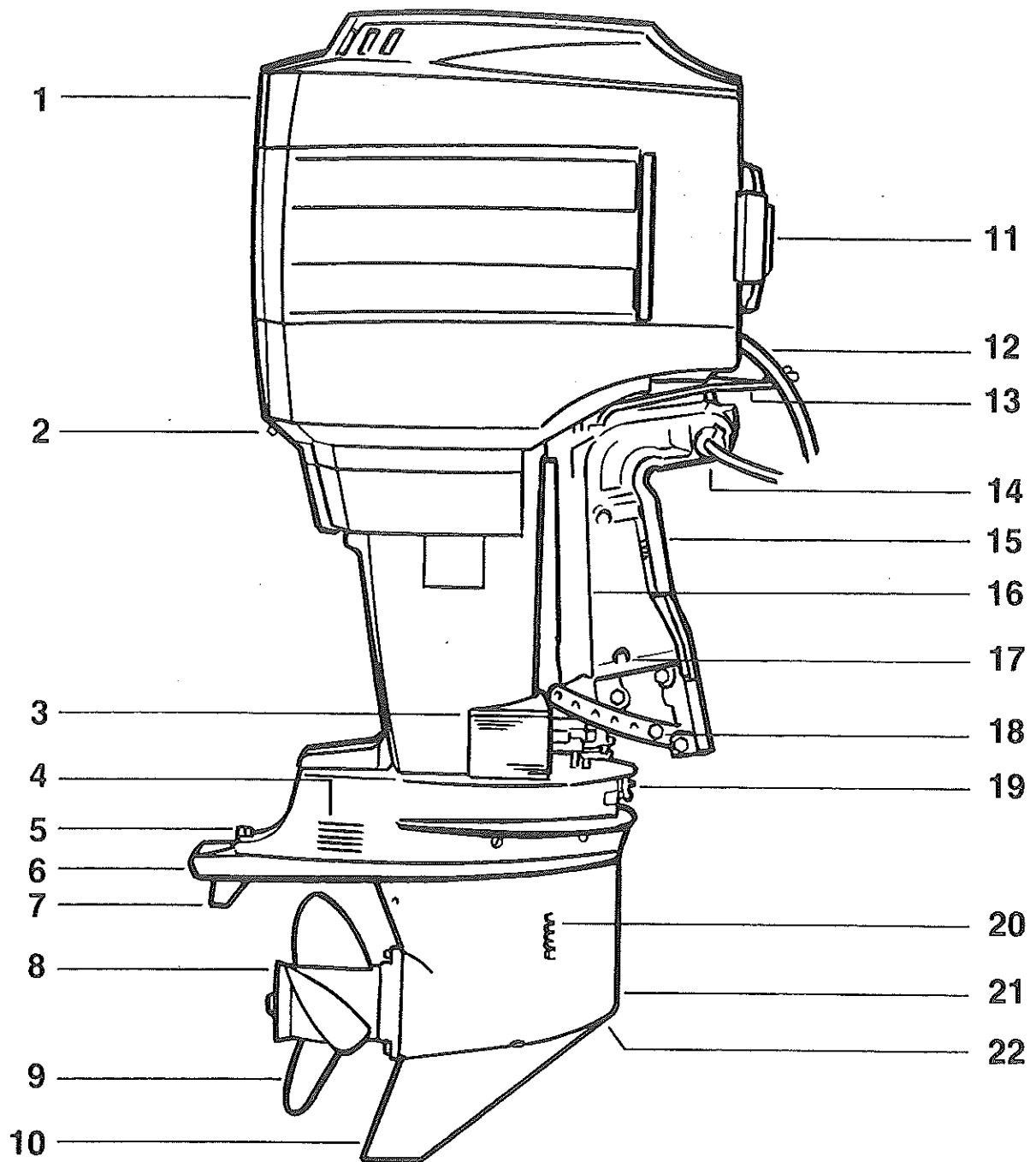

- |                              |  |
|------------------------------|--|
| 1. Cowl Halves               | 13. Steering Arm   |
| 2. "Tell-Tale" Outlet        | 14. Tilt Tube  |
| 3. Drive Shaft Housing Mount | 15. Transom Mounting Bracket                               |
| 4. Water Discharge           | 16. Serial Plate Location<br>(Port Side)                   |
| 5. Trim Tab Adjust Screw     | 17. Swivel Bracket   |
| 6. Anti-Ventilation Plate    | 18. Tilt Pin (Trim Adjustment Bolt -<br>Power Trim Models) |
| 7. Trim-Tab                  | 19. Speedometer Tube                                       |
| 8. Exhaust                   | 20. Water Intake   |
| 9. Propeller                 | 21. Speedometer Pickup                                     |
| 10. Skeg                     | 22. Gear Housing   |
| 11. Cowl Latch               |  |
| 12. Wiring Harness           |  |

# SPECIFICATIONS

MODEL	75	90
Horsepower	75	90
Propshaft Kilowatts <sup>1</sup>	56	67
Full Throttle RPM Range	4750-5250	5000-5500
Idle Speed	650-700 RPM (in Gear)	
Piston Displacement	71.12 Cu.In. (1165.7cc)	
Bore	3.375 in. (85.7mm)	
Stroke	2.65 in. (67.3mm)	
Recommended Spark Plug	NGK-BUHW - 2 or AC - V40FFK or Champion L78V [Use Champion QL78V Where Radio Frequency Interference (RFI) Suppression is Required]	
Recommended Gasoline	Leaded or Unleaded (Lead-Free) Gasoline. With a minimum posted octane rating of 87 (Research Octane Number 90).	
Recommended Oil	Quicksilver 2-Cycle Outboard Oil	
Battery Requirements	Minimum Reserve Capacity Rating of 100 Minutes and Cold Cranking Amperage of 350 Amperes	
Transom Height	Long Shaft = 20 in. (508mm) Extra Long Shaft = 25 in. (635mm)	

<sup>1</sup> Measured at the propshaft in accordance with ICOMIA 28.

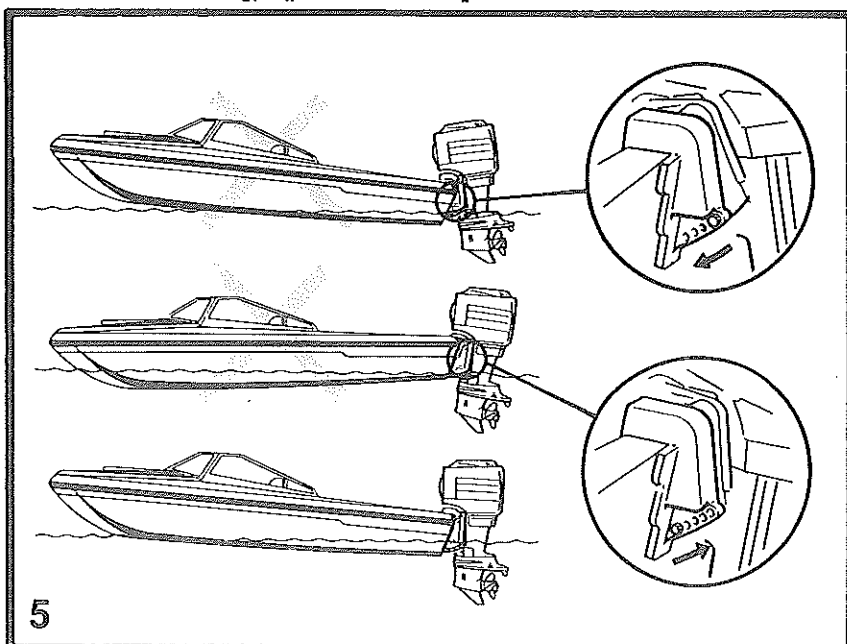
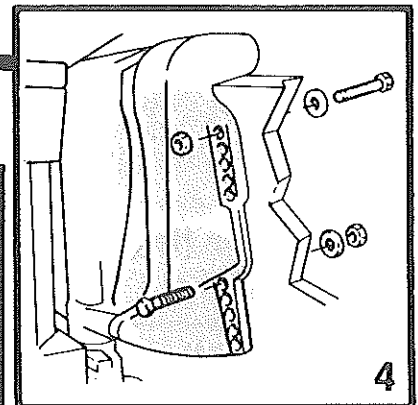
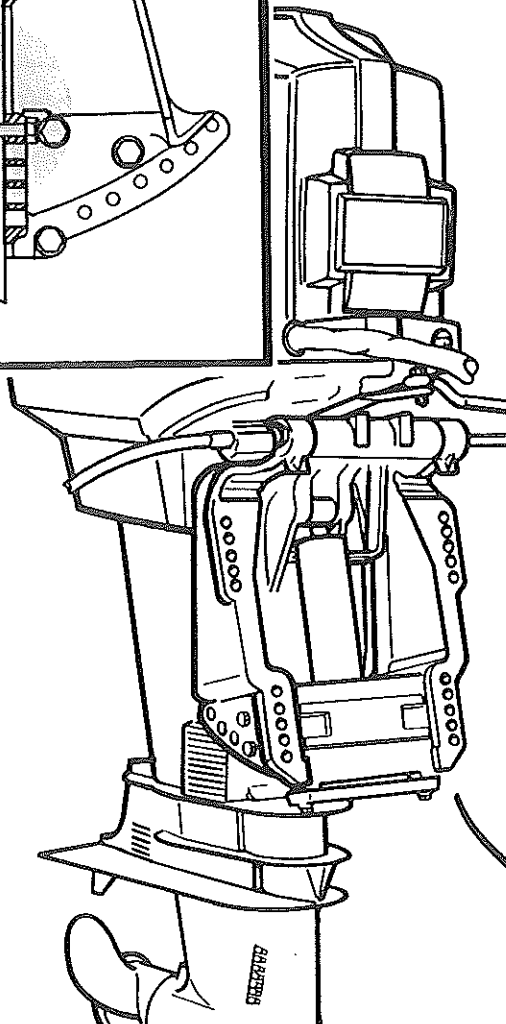
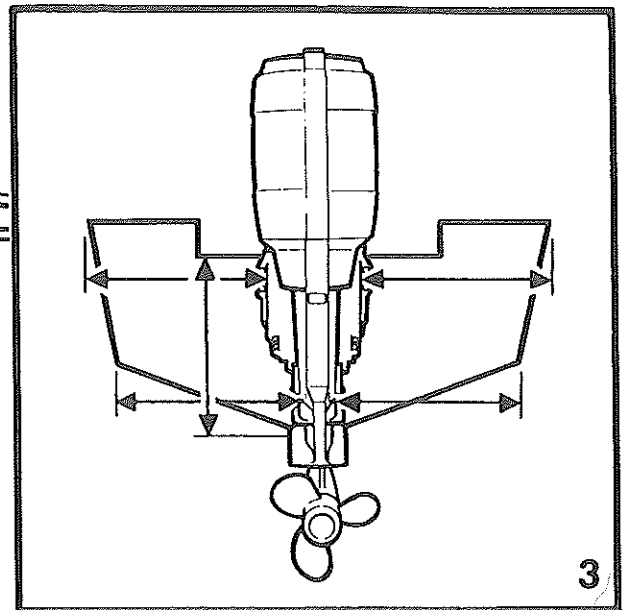
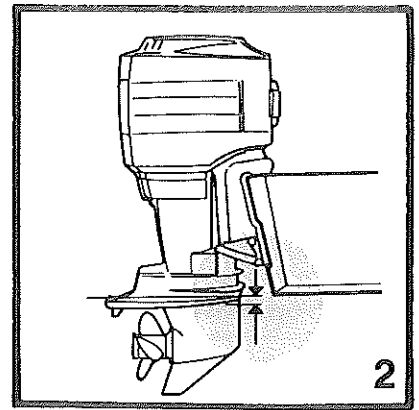
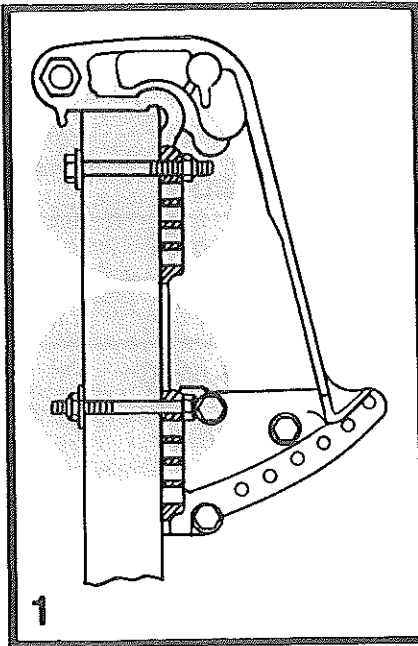

# MOTOR INSTALLATION



## WARNING

**DO NOT OVERPOWER** - Most boats are rated and certified for the maximum horsepower capabilities of the boat. Refer to the boat "Certification Plate" for the maximum horsepower limit. If in doubt, contact your dealer.

**IMPORTANT:** For proper boat operation, position the engine on the boat transom in relation to the boat bottom and according to procedures explained in the "Engine Mounting Instructions".



## CAUTION

**WE DO NOT** recommend engine mounting heights in excess of 25 inches (30 inches on XL models). Excessive mounting heights require that extreme care be taken to ensure proper water flow for engine cooling.

## TRANSOM HEIGHT



## WARNING

**1** Before operating, motor(s) **MUST BE SECURED** to boat with bolts and mating nuts, as follows:

- Four 1/2" (12.7mm) hex head bolts into holes at top and bottom of clamp brackets.

- Failure to bolt motor to transom may result in damage to boat and/or loss of motor and possible injury to occupants of boat.

**2** Proper transom height is important for best boating performance. The gear housing anti-ventilation plate should be parallel to the boat bottom and flush to 1.5" (38mm) below boat bottom.

**NOTE:** When the engine is rigged on the transom of a 20" transom height boat, the cavitation plate will be 1" below the bottom.

Running the engine while trimmed down may cause undesirable spray on some boats. If so, and you do not wish to run trimmed further out, raise the engine on the transom by one bolt hole (3/4" increase in height).

For boats in the over 50 MPH class, raising the outboard higher than standard on the transom will:

- A. Decrease steering torque.
- B. Increase top speed as the engine is raised, due simply to a reduction in gear housing drag.
- C. Improve boat handling and stability.



## WARNING

A light, very fast boat, running on a small segment of its bottom, requires close concentration and coordination on the part of the driver in order to maintain top speed in a relatively safe manner.

- D. Increase the opportunity for "ventilation" particularly when planing off. (Above a 22" (55.9cm) installation, a sharpened, hi-rake, steel propeller, designed for surface operation, is recommended.)

## Centerline

**3** Center motor on boat transom.

## Securing Motor

Place motor on centerline of transom and drill through transom using upper bolt holes in swivel bracket as guides.

**4** Secure motor to transom with bolts, nuts and washers provided.

## TILT (ANGLE) ADJUSTMENT

**5** Tilt angle of the lower unit has a distinct effect on performance and handling. Adjust by changing location of tilt pin until boat rides level.



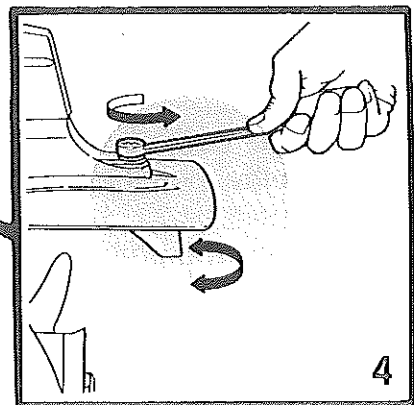
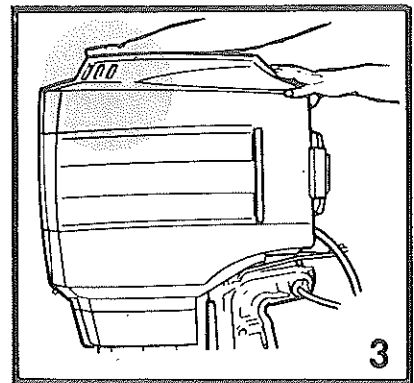
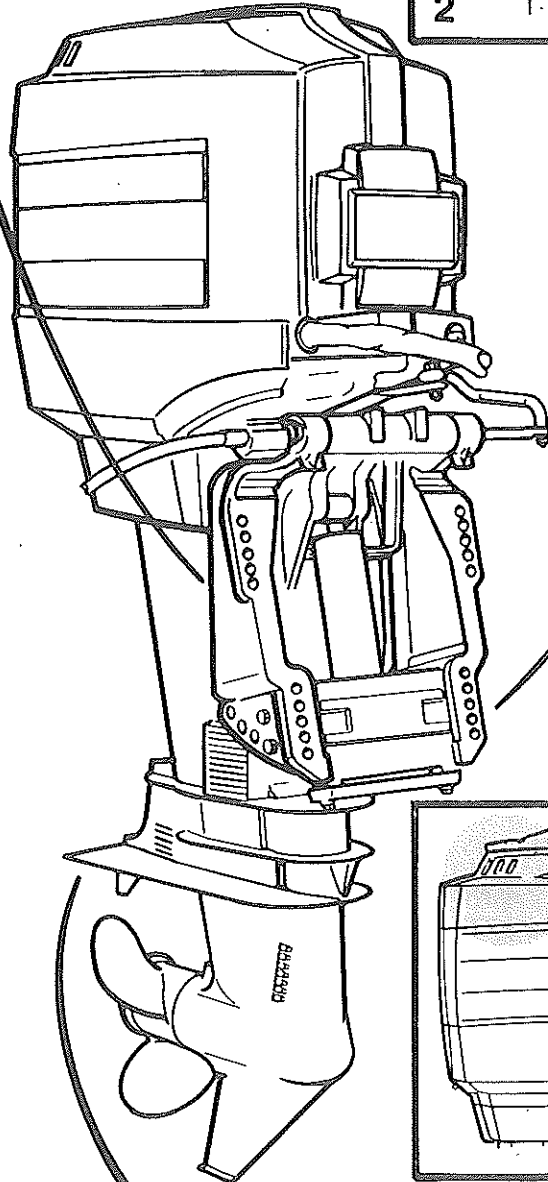
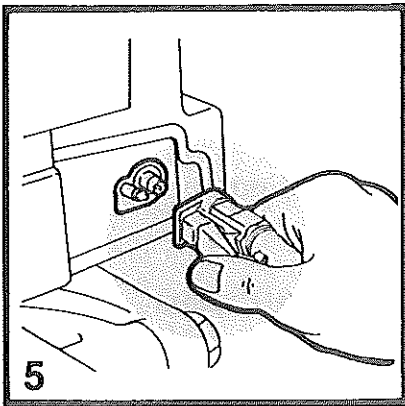
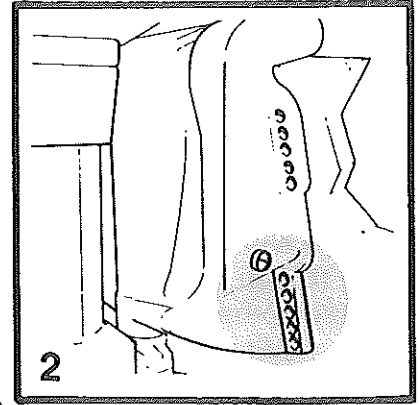
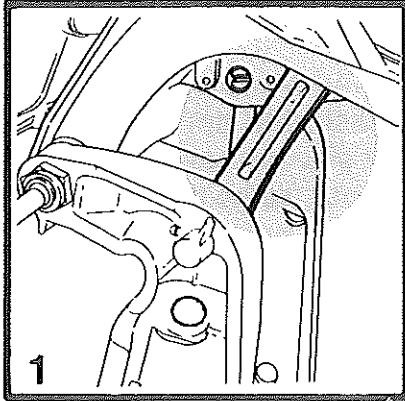

# MOTOR INSTALLATION

## (Continued)

**IMPORTANT:** Propeller shaft tilt will affect boat performance. With the motor tilted in, propeller force will make the boat want to go into a right-hand turn. The situation reverses when the lower unit is tilted out well past vertical. The operator must resist this force to keep the boat on a straight course. Refer to TRIM TAB ADJUSTMENT.

**IMPORTANT:** DO NOT operate motor with tilt bolt removed.

With Power Trim - place tilt bolt 1 hole closer to transom.

**Tilt Lock Lever**  
(Standard on Non-Power Trim Models)

1 Locks motor in a fully tilted position.



### CAUTION

Engine must not be run in full tilt lock position, as water pickup in lower unit would be out of the water, and water pump and/or engine would be damaged.

**DO NOT** use tilt lock lever when TRAILERING boat/motor UNLESS lower unit is supported with a block of wood.

**To tilt motor up/out:**

Shift motor into FORWARD gear.

2 With Power Trim - Rotate release valve control knob fully counterclockwise.

3 Pull forward on top cowl or lift up on lower unit and lock motor in full tilt position by turning tilt lock lever knob.

**To disengage tilt:**

Tilt motor as far as possible. Turn tilt lock lever knob and lower motor to normal operating position.

With Power Trim - Rotate release control valve knob fully clockwise.

**IMPORTANT:** The trim tab is made of a special alloy to protect motor housings from galvanic corrosion. DO NOT paint or place protective coating on the trim tab.

## TRIM TAB ADJUSTMENT

4 The trim tab will help to offset steering pull caused by propeller torque at high speeds or extreme tilt angles. If boat pulls to the left, loosen cap screw and rotate trailing edge of trim tab to the left (as viewed from behind motor). If boat pulls to the right, rotate trim tab to right. Tighten cap screw.

## BATTERY AND ELECTRICAL ACCESSORIES



### CAUTION

Failure to observe correct polarity when connecting battery leads to battery will result in damage to the charging system on electric starting models.

**IMPORTANT:** Secure battery in a favorable position in the boat.

Any accessories, such as horns, lights, etc., should be properly fused and installed with connections attached directly to battery terminals.

## MOUNTING FUEL TANK AND CONNECTING FUEL LINES

Arrange fuel line so that it does not become twisted, kinked, pinched or stretched.

5 Connect fuel line to outboard. Make sure fuel line connector is locked on outboard fuel connector.

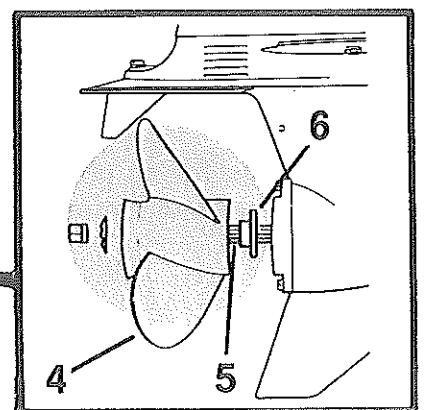
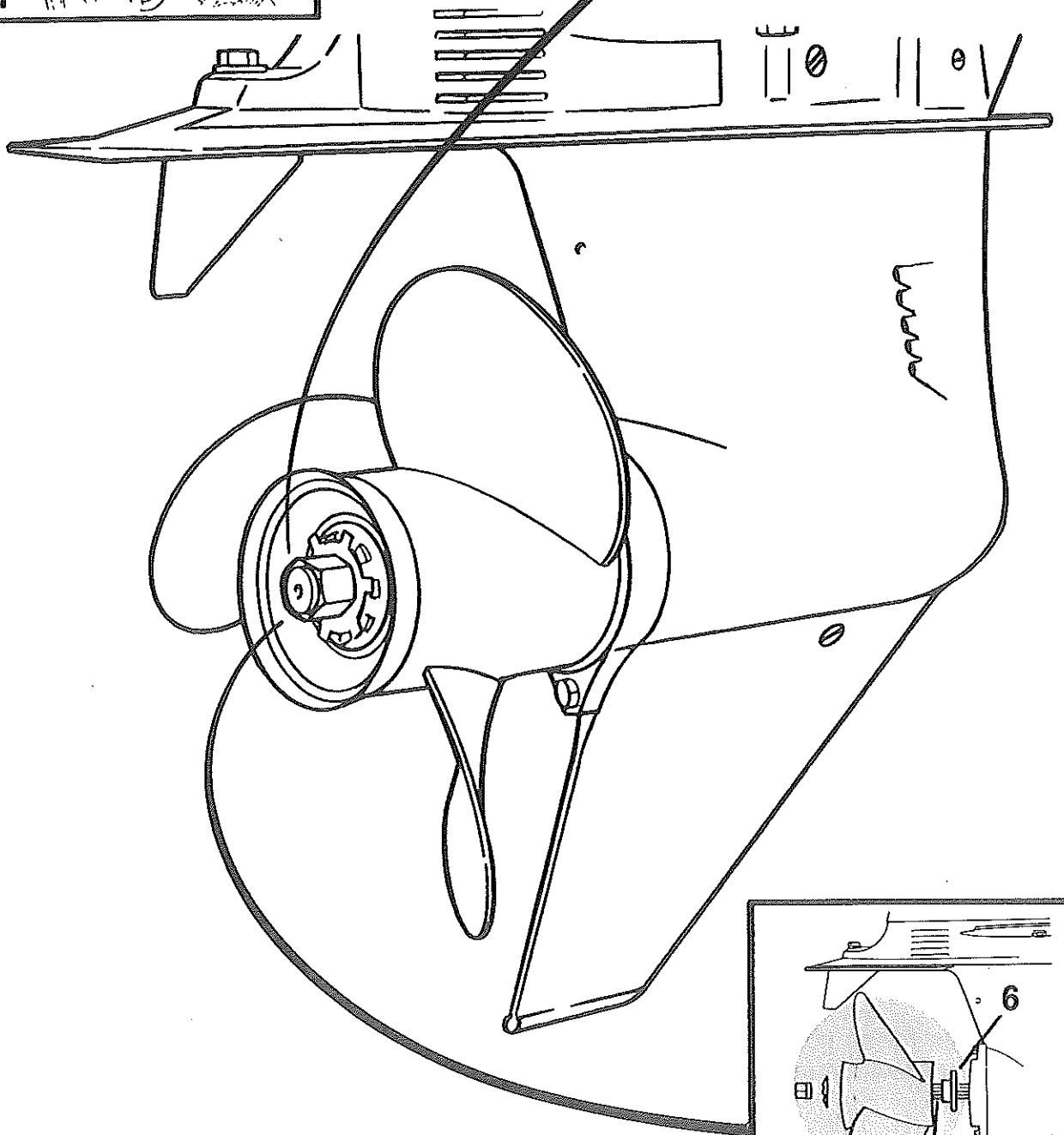
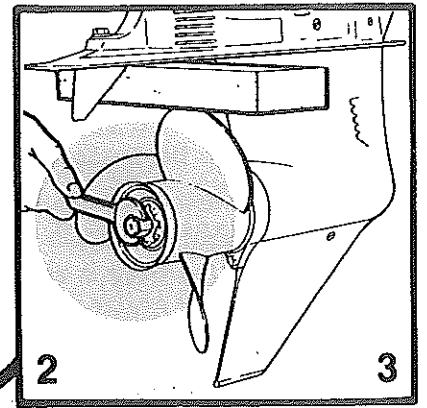
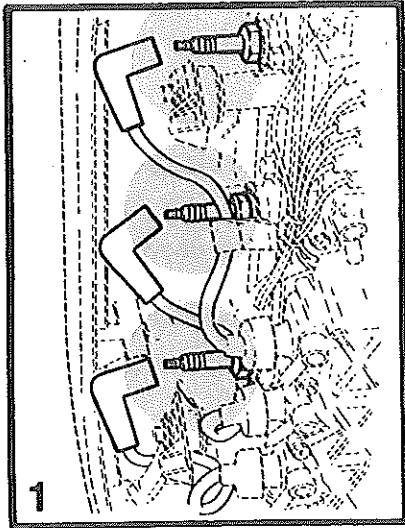

# PROPELLERS

## PROPELLER SELECTION

Select a propeller that will allow the engine to operate at or near the top of the recommended full throttle RPM range with a normal load. Maximum engine speed (RPM) for propeller selection exists when boat speed is maximum and trim is minimum for the speed. (High RPM, caused by an excessive trim angle, should not be used in determining correct propeller.) Normally, there is a 300 to 500 RPM change between propeller pitches. Full throttle RPM range is listed in SPECIFICATIONS.

If the engine RPM during full throttle operation is below the recommended range listed in SPECIFICATIONS, the propeller **MUST BE** changed to prevent loss of performance and possible engine damage.

For better acceleration, such as is needed in waterskiing, propping up to 200 RPM above the recommended range is advised. Continuous operation above the recommended maximum RPM, however, is not permissible.

After initial propeller installation, the following common problems may require that the propeller be changed to a lower pitch:

- Warmer weather and greater humidity cause an RPM loss.
- Operating in a higher elevation causes an RPM loss.
- Operating with a damaged propeller or dirty boat bottom or gear housing cause an RPM loss.
- Operating with an increased load (additional passengers, pulling skiers, etc.).

For dual installation, try the next higher pitch propeller. For waterskiing, use next lower pitch propeller; however, do not operate at full throttle when using ski propeller but not pulling skiers.

Propellers are available for specific boating requirements. Consult your Authorized Dealer for recommendations.

## PROPELLER REMOVAL



### WARNING

**Before attempting to remove or install propeller, remove spark plug leads from spark plugs to prevent engine from starting accidentally.**

- 1** Remove cowl (see COWL REMOVAL AND INSTALLATION) and disconnect spark plug leads.
- 2** Place wood block between propeller blade and anti-ventilation plate to prevent rotation. Straighten bent tabs on tab washer.
- 3** Turn propeller shaft nut counterclockwise to remove nut.
- 4** Slide tab washer, propeller and thrust hub off propeller shaft.

## PROPELLER REPAIR

Some damaged propellers can be repaired. Consult your Authorized Dealer.

## PROPELLER INSTALLATION

**IMPORTANT: Periodically check propeller nut for tightness during boating season. A minimum of 55 lb. ft. (75 N·m) torque is required.**

- 5** Apply a liberal coat of one of the following Quicksilver lubricants to the propeller shaft: Special Lubricant 101 or 2-4-C Marine Lubricant.
- 6** Slide thrust hub onto propeller shaft with thrust hub shoulder toward gear housing.

Slide propeller onto shaft. Place tab washer onto shaft and install propeller shaft nut. Place a wood block between propeller blade and anti-ventilation plate to prevent rotation. Turn propeller shaft nut clockwise. **TIGHTEN NUT SECURELY.** A minimum of 55 lb. ft. (75 N·m) torque is required. Bend three tabs of tab washer down into grooves on propeller hub. Reconnect spark plug leads and install cowl. Retorque nut after first use.

# CONDITIONS AFFECTING OPERATION

## WEIGHT DISTRIBUTION

Positioning of weight (passengers and gear) inside the boat has the following effects:

- A. Shifting weight to rear (stern).
  - Generally increases speed and engine RPM.
  - At extremes, can cause boat to porpoise.
  - Causes bow to bounce in choppy water.
  - Increases danger of the following wave splashing into boat when coming off plane.
- B. Shifting weight to front (bow).
  - Improves ease of planing off.
  - Improves rough water ride.
  - At extremes, can cause boat to veer back and forth (bow steer).

## BOTTOM OF BOAT

To maintain maximum speed the following conditions of the boat bottom should be observed:

- A. Clean, free of barnacles and marine growth.
- B. Free of distortion; nearly flat where it contacts the water.
- C. Straight and smooth, fore and aft.

## GEAR HOUSING

If motor is not tilted up when boat is docked, marine vegetation may accumu-

late. This growth **MUST BE REMOVED** before operation; it may clog water inlets and cause engine to overheat.

## CAVITATION

Cavitation occurs when water flow cannot follow the contour of a fast-moving underwater object, such as a gear housing or propeller. Cavitation permits the propeller to speed up, but the boat speed to reduce. Cavitation can seriously erode the surface of the gear housing or propeller. Common causes of cavitation are:

- A. Bent propeller blade or damaged gear housing skeg.
- B. Raised burrs or sharp edges on propeller or gear housing.
- C. Weeds or other debris snagged on propeller or gear housing.

## VENTILATION

Ventilation is caused by surface air or exhaust gases which are introduced around the propeller resulting in propeller speed-up and a reduction in boat speed. Excessive ventilation is annoying and usually caused by:

- A. Outboard installed too high on transom.
- B. Outboard tilted out too far.
- C. A missing propeller diffuser ring.
- D. A damaged propeller or gear housing, which allows exhaust gases to escape between propeller and gear housing.

# FUEL MIXTURE AND FUEL/OIL RECOMMENDATIONS



## WARNING

**USE CARE** when transporting fuel container, whether in a boat or car. **DO NOT** fill fuel container to maximum capacity. Gasoline will expand considerably as it warms up and can build up pressure in the fuel container. This can cause fuel leakage and a potential fire hazard.

## GASOLINE RECOMMENDATIONS



## CAUTION

Use of improper gasolines and/or oils can cause serious damage to your outboard motor.

Any leaded or unleaded (lead-free) gasoline, with a minimum posted octane rating of 87 (research octane number 90) is satisfactory for use in these model outboard motors.

However, gasolines containing alcohol, either methyl alcohol (methanol) or ethyl (ethanol) may cause increased:

- Corrosion of metal parts.
- Deterioration of elastomer and plastic parts.
- Fuel permeation through flexible fuel lines.
- Wear and damage of internal engine parts.
- Starting and operating difficulties.

Some of these adverse effects are due to the tendency of gasolines containing alcohol to absorb moisture from the air, resulting in a phase of water and alcohol separating from the gasoline in the fuel tank.

The adverse effects of alcohol are more severe with methyl alcohol (methanol) and are worse with increasing alcohol content.



## WARNING

**FIRE AND EXPLOSION HAZARD:** Fuel leakage from any part of the fuel system can be a fire and explosion hazard which can cause serious bodily injury or death. Careful periodic inspection of the entire fuel system is mandatory, particularly after storage. All fuel components including fuel tanks, whether plastic, metal or fiberglass, fuel lines, primer bulbs, fittings, fuel filters and carburetors should be inspected for leakage, softening, hardening, swelling or corrosion. Any sign of leakage or deterioration necessitates replacement before further engine operation.

Because of the possible adverse effects of alcohol in gasoline, it is recommended that only alcohol-free gasoline be used where possible. If only alcohol-containing fuel is available, or if the presence of alcohol is unknown, then increased inspection frequency for leaks and abnormalities is required.

## OIL RECOMMENDATIONS



## CAUTION

The use of other than recommended gasoline and Quicksilver 2-Cycle Outboard Oil or an acceptable NMMA TC-W II™ oil may cause piston scoring, bearing failure or both. **DO NOT**, under any circumstances, use multi-grade or other highly detergent automobile oils or oils which contain metallic additives.

In an emergency, if Quicksilver 2-Cycle Outboard Oil is not available, substitute a high quality 2-cycle oil that is intended for outboard use and meets NMMA rating TC-W II™, shown on oil container. Use the oil manufacturer's recommended gasoline-oil mixture as shown on the label.

# FUEL MIXTURE AND FUEL/OIL RECOMMENDATIONS

(Continued)

## BREAK-IN PROCEDURE

During the break-in period, operate your new outboard motor on the first 30 gallons of fuel by mixing gasoline-oil in the fuel tank at a 50:1 ratio as described in chart above.

NOTE: The 50:1 ratio gasoline-oil in the fuel tank combined with the metered oil ratio supplied by the oil injection system will supply the necessary gasoline-oil mixture required for break-in lubrication.

Operate your new outboard motor at varied throttle settings not to exceed 1/2 throttle (2500-3500 RPM) on the first 10 gals. with 50:1 mixture fuel. Operate your new outboard with the remaining 20 gals. of 50:1 mixture fuel at any speed, although sustained operation at full throttle should be avoided until all 30 gals. of fuel have been consumed. After the break-in with 50:1 ratio fuel, it is no longer necessary to mix oil to the gasoline in the remote fuel tank.

## BREAK-IN 50:1 FUEL MIXTURE

Type of Oil	U.S. Measure	Imperial Measure	Metric Measure
Quicksilver 2 Cycle Outboard Oil	16 U.S. oz. to each 6 gallons of gasoline	15 Imp. oz. to each 5 Imp. gallons of gasoline	400cc to each 20 liters of gasoline
Other Acceptable NMMA TC-W II™ Oils	Use at Oil Manufacturer's Recommendations. DO NOT EXCEED 50:1		

## OIL INJECTION SYSTEM

### Oil Tank Capacity

Tank Capacity ..... 1 gal. (3.75 liters)

Maximum Operation at Full  
Throttle ..... 6 hrs.

### Oil Remaining When Warning

Buzzer Sounds ..... 1 qt. ( liter)

Approximate Running Time Remaining  
at Wide Open Throttle When  
Buzzer Sounds ..... 1 hr.

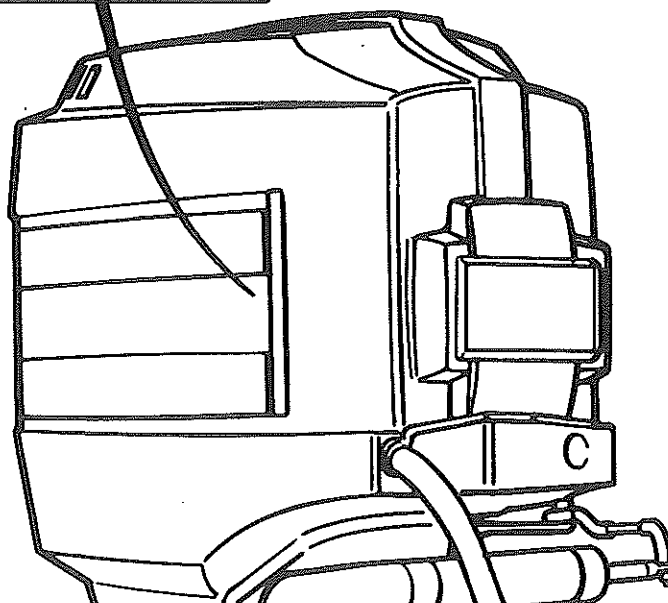
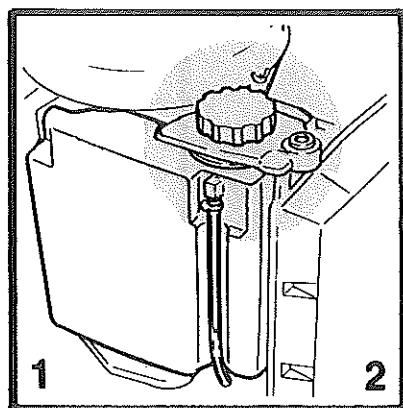

## FUEL MIXTURE AND FUEL/OIL RECOMMENDATIONS (Continued)

### Filling Oil Injection System



**WARNING**  
Warning horn sounds momentarily as a test whenever you switch key from OFF to ON. Horn sounds intermittently to indicate low oil supply. Horn sounds steadily to indicate engine overheating. **DO NOT IGNORE SIGNAL HORN.** Permanent damage to engine will result if the cause of an alarm is not immediately identified and corrected.

Open starboard cowl and secure with brace. (Refer to COWL REMOVAL AND INSTALLATION.)

**1** Check oil level using sight gauge on oil tank.

**2** Unscrew tank cap and fill tank full with Quicksilver 2-Cycle Outboard Oil or NMMA approved TC-W II™ prediluted oil only.

Replace cap tightly and close cowls.



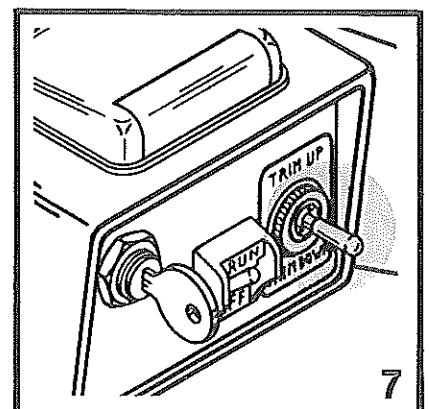
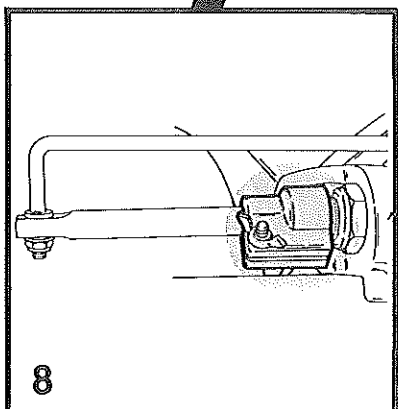
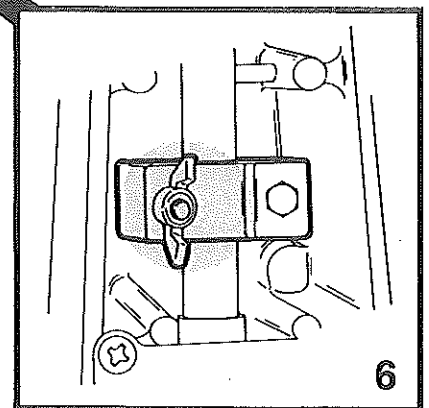
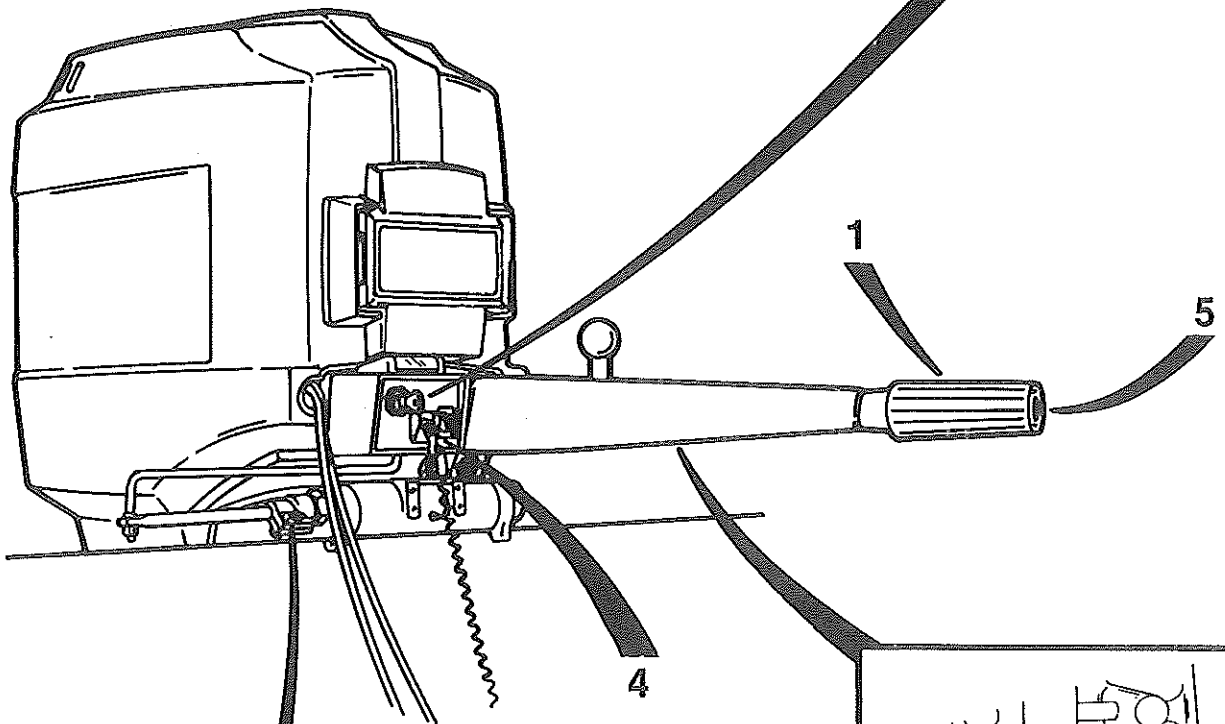
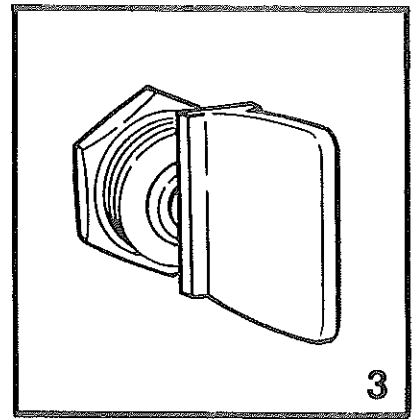
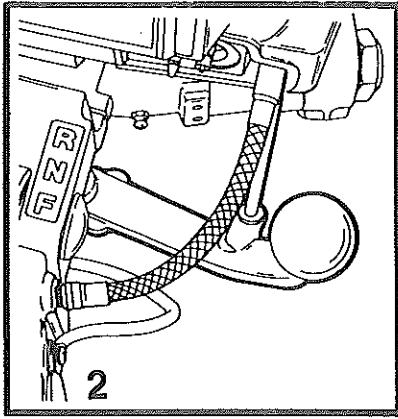

# OUTBOARD MOTOR CONTROLS TILLER HANDLE MODELS

**1** Tiller Handle/Throttle Twist Grip - Provides a means to steer boat and control engine speed

**2** Shift Handle - Provides gear selection of lower unit. "F" - Forward  
"N" - Neutral  
"R" - Reverse

**3** Ignition/Choke Switch - Turns engine ON and OFF, actuates electric starter motor, actuates carburetor enrichener and sounds alarm horn momentarily to test warning circuits.

**4** Lanyard Stop Switch - Refer to page 1 for explanation. The lanyard cord/clip, when used with the lanyard stop switch **MUST BE** connected to boat driver. Should driver be unable to reach the tiller handle/controls, the lanyard cord/clip will be pulled from lanyard stop switch and the engine will shut OFF. This lanyard stop switch **SHOULD NOT BE USED** as normal engine shut-off.

**IMPORTANT:** The Lanyard Stop Switch can be repositioned to RUN with or without lanyard cord/clip so that engine can be restarted.

**5** Stop Button - Used as normal engine shut-off. When engine stops ignition key **MUST** also be turned to OFF position.

**6** Throttle Friction Wing Nut - Adjusts twist grip friction to hold throttle at desired boat speed. Turn nut clockwise to increase friction, counterclockwise to decrease friction.

**7** Trim/Tilt Switch - Trim outboard out (up) by pressing up on switch; trim outboard in (down) by pressing down on switch.

**8** Co-Pilot - Provides friction control in the steering mechanism. Recommended adjustment is such that the co-pilot will remain in a fixed course position (during normal operation) without the need of manual control, yet will not be too tight to allow free and easy steering. Turn the wing nut clockwise to increase friction; turn counterclockwise to decrease friction.



## WARNING

If co-pilot wing nut is overtightened it may not be possible to steer the outboard in an emergency.

# OPERATION TILLER HANDLE MODELS

## WARNING HORN OPERATION

This engine is equipped with a warning system to signal engine overheat and low oil level in the oil injection system.

The warning horn is located inside of side mount remote control. If boat is equipped with a panel or console remote control, the warning horn is incorporated behind the key switch in the key switch wiring harness.

Each time the key switch is turned from the "OFF" position to the "ON" position the warning horn will sound momentarily. This indicates that the warning system will function when the engine is running.



## CAUTION

If the warning horn fails to sound momentarily when the key switch is turned from the "OFF" position to the "ON" position or continually sounds, see an Authorized Dealer. **DO NOT** operate the engine.

The warning system gives the following indications:

**MOMENTARY BEEP** (when key switch is turned on) - circuit test of warning system.

**STEADY BEEP** - Engine is overheated.

**INTERMITTENT BEEP** - Oil injection oil level low.

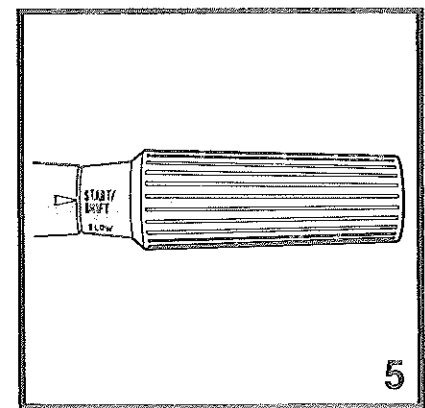
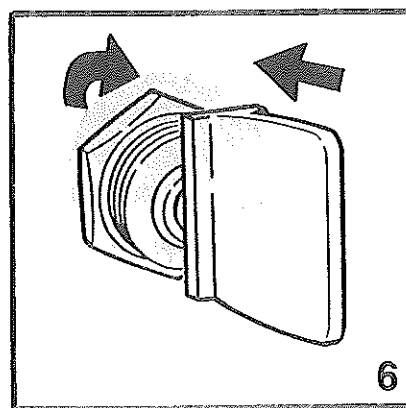
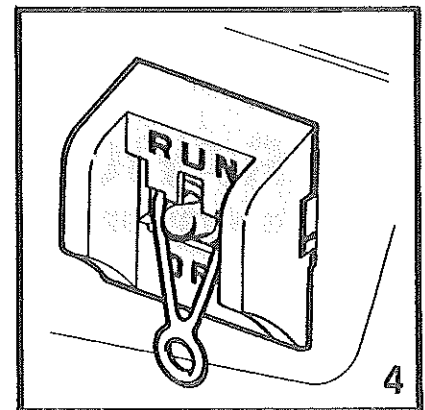
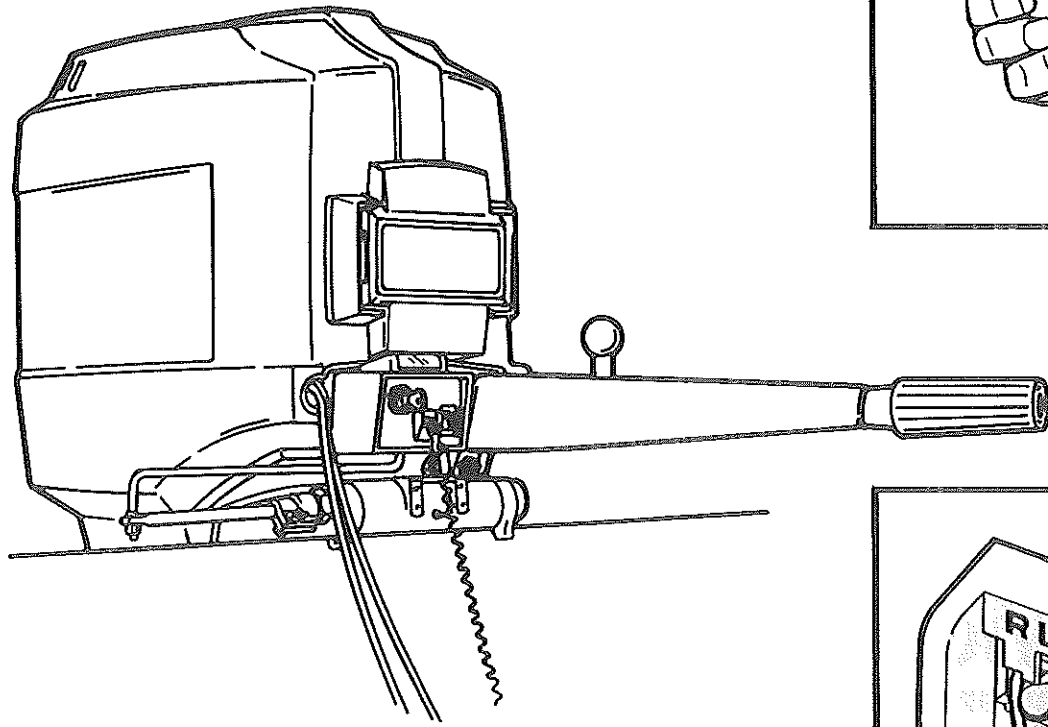
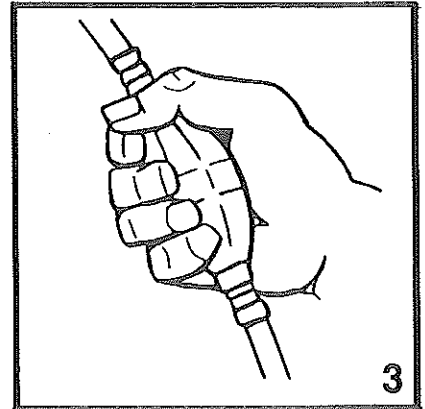
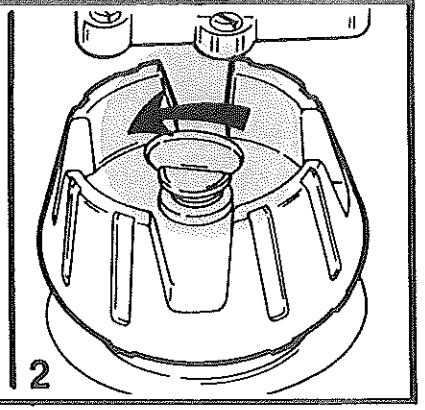
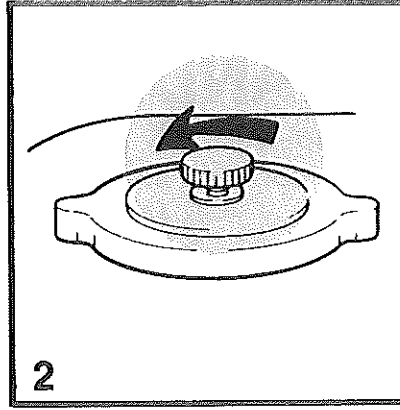
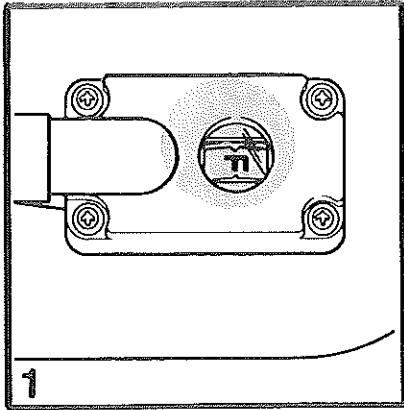

# OPERATION TILLER HANDLE MODELS (Continued)

## BEFORE STARTING

 **CAUTION**  
**OPERATOR and PASSENGERS SHOULD BE SEATED WHENEVER ATTEMPTING to START the ENGINE.**

 **CAUTION**  
**DO NOT ATTEMPT start-up BEFORE launching boat. DO NOT operate outboard out-of-water. Serious damage to outboard could result from overheating.**

 **WARNING**  
**Before attempting to start engine, MAKE CERTAIN that outboard is shifted into NEUTRAL and that area around boat is clear (to get underway).**

Tilt outboard to vertical position.

- 1 Check fuel tank for sufficient fuel and that tank is secure in boat.
- 2 Open air vent on fuel tank cap.
- 3 Squeeze fuel primer bulb until it is firm.
- 4 Check that lanyard stop switch is in RUN position.
- 5 Position throttle twist grip to START and shift handle to NEUTRAL.

Turn key from OFF to ON to test warning circuit. The alarm horn should sound only momentarily. If it does not, contact an Authorized Dealer.

 **CAUTION**  
**DO NOT operate starter motor for longer than 30 seconds or starter motor may be damaged. Allow at least 2 minutes between starting attempts.**

**IMPORTANT: Starter circuit is protected by SFE 20 AMP fuse on starboard side of engine. If starter fails to operate, check for blown fuse. BEFORE replacing fuse, locate and correct cause of overload.**

## STARTING COLD ENGINE

**6** Turn key clockwise to RUN position and push in on key to activate enrichener. Hold key in the pushed in position for 4 to 6 seconds, then turn key clockwise past RUN position to START.

As soon as engine starts, allow key to return to RUN position and release enrichener. If engine falters, push in on key to actuate enrichener again.

 **CAUTION**  
**Be prepared to alter throttle setting when engine starts. DO NOT allow engine to exceed 2500 RPM while in NEUTRAL.**

## STARTING WARM ENGINE

Turn key clockwise past RUN position to START. As soon as engine starts, allow key to return to RUN position. If engine falters, push in on key to actuate enrichener.

**NOTE: If engine fails to start, follow STARTING COLD ENGINE procedure.**

 **CAUTION**  
**Be prepared to alter throttle setting when engine starts. DO NOT allow engine to exceed 2500 RPM while in NEUTRAL.**

## AFTER STARTING

Turn throttle grip to SLOW position.

Check for steady stream of water from water pump "Tell-Tale". If intermittent or no flow is observed, STOP ENGINE IMMEDIATELY. Check "Tell-Tale" stream often during motor operation.

 **CAUTION**  
**A continuous warning horn will sound if engine overheats. Stop engine immediately if alarm sounds. Locate and remedy cause of overheating before using motor.**

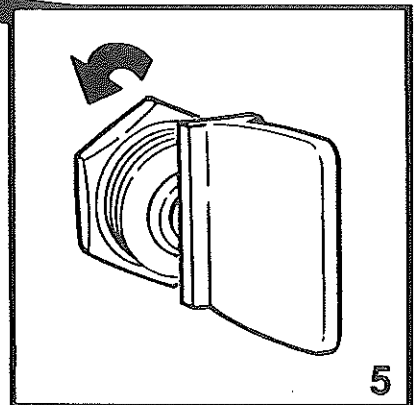
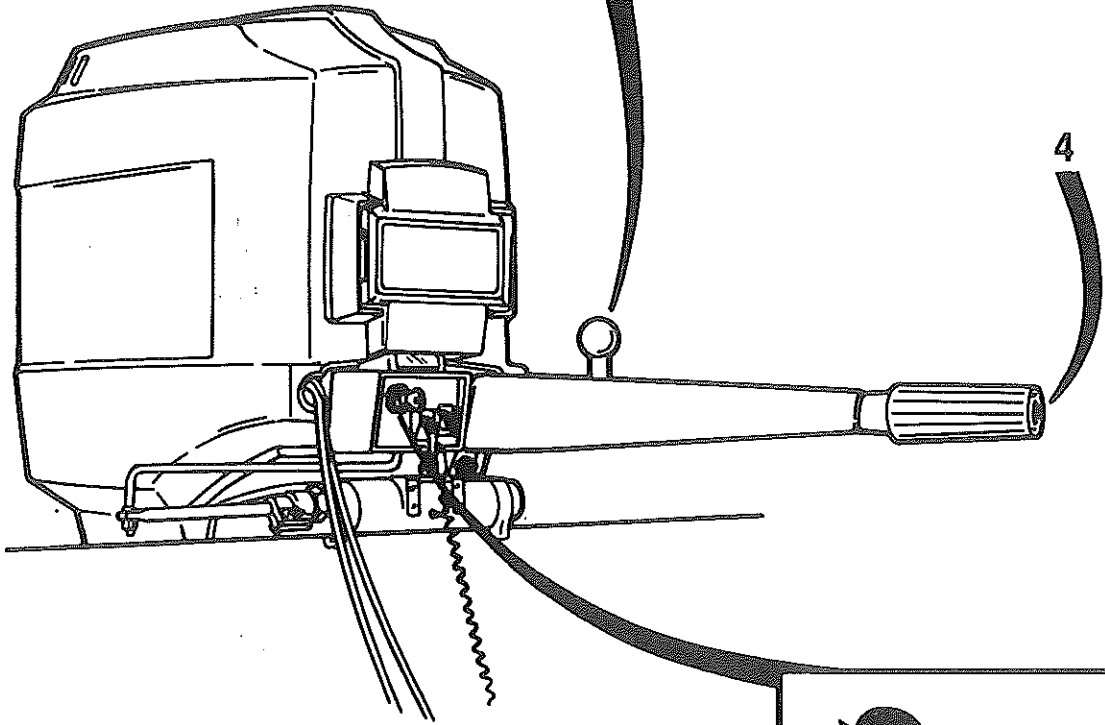
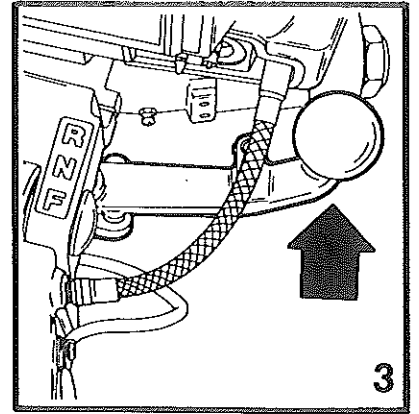
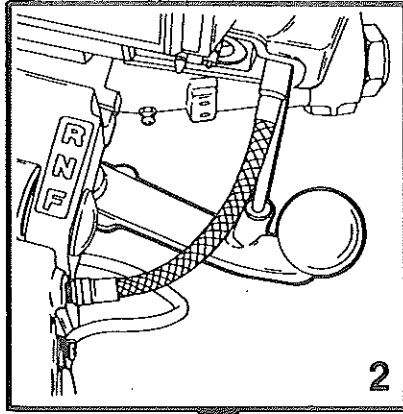
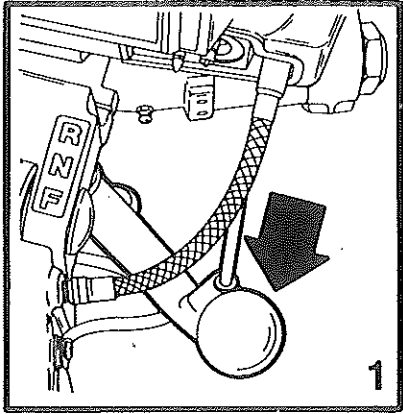

# OPERATION TILLER HANDLE MODELS (Continued)

## THROTTLE/SHIFTING GEARS

**DO NOT** attempt to shift outboard into **REVERSE** gear **WHEN ENGINE IS NOT RUNNING**. Damage to the shift mechanism could result.



### CAUTION

When engine is running, throttle twist grip **MUST BE** between **SLOW** and **SHIFT** positions before shifting into or out of gear. Shift gears with a firm, quick motion to avoid "gear chatter."

**1** FORWARD GEAR "F" - Position throttle twist grip between **SLOW** and **SHIFT** positions, then pull forward on shift handle to engage gear. Rotate twist grip counterclockwise to increase speed.

**2** Neutral "N" - Position throttle twist grip between **SLOW** and **SHIFT** positions, and place shift handle to "N" Neutral.



### CAUTION

Exercise extreme care when operating in **REVERSE GEAR**. **DO NOT** operate motor at high speeds when in **REVERSE**.

**3** REVERSE GEAR "R" - Position throttle between **SLOW** and **SHIFT** positions, then push back on shift handle to engage gear. Rotate twist grip counterclockwise to increase speed.

## STOPPING

**4** Press Stop Button at end of throttle twist grip and hold until engine stops.

**IMPORTANT:** In an emergency the engine can be stopped at any speed, in or out of gear. For normal stopping, idle engine and shift to **NEUTRAL** before pressing **STOP BUTTON**.

**5** Turn ignition key counterclockwise to **OFF** position.

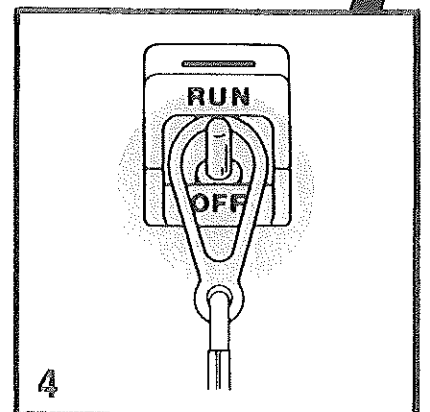
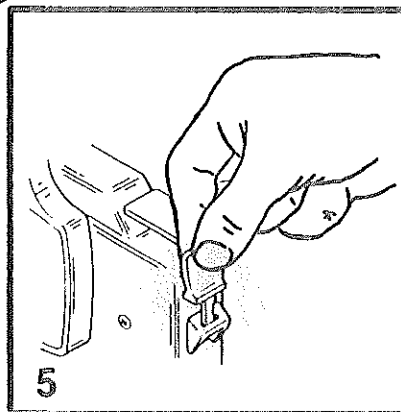
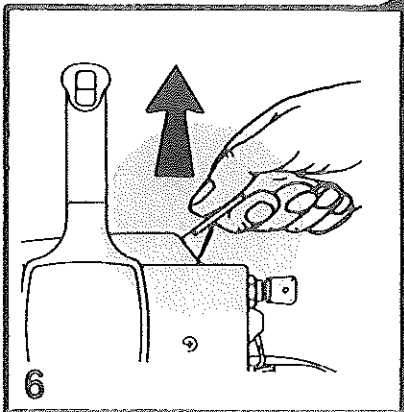
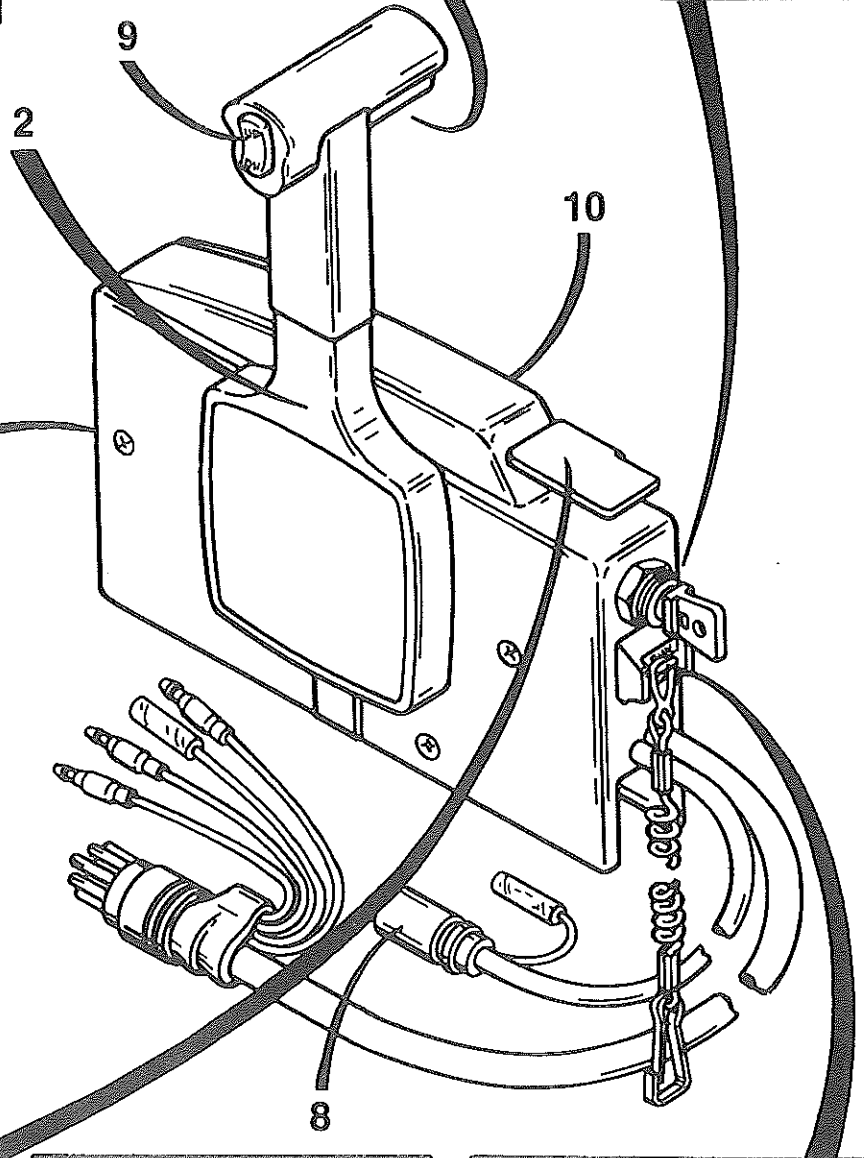
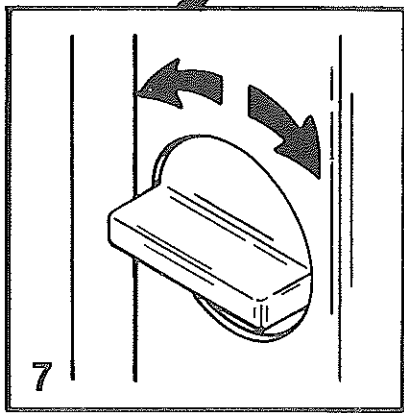
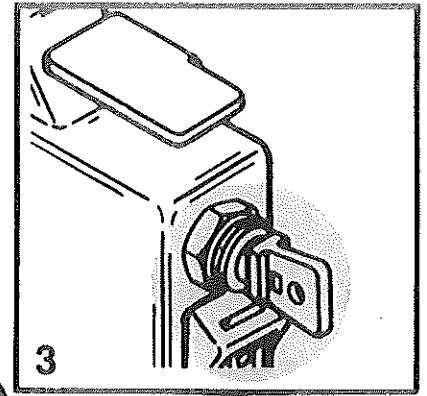
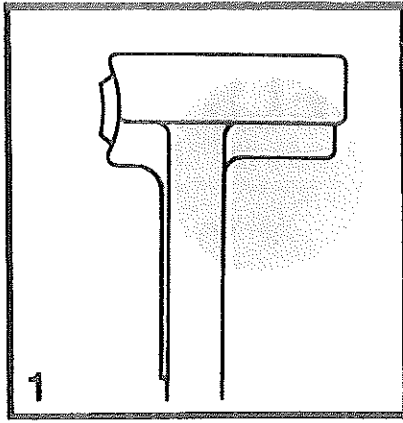

# QUICKSILVER SIDE MOUNT REMOTE CONTROL COMPONENTS

**1** Neutral Lock Bar - prevents accidental shift and throttle engagement. Bar must be squeezed before control handle can be moved, from NEUTRAL.

**2** Control Handle - controls forward, reverse motion and engine speed.

**3** Ignition/Choke Switch - turns engine ON and OFF, actuates electric starter motor, actuates carburetor enrichener and sounds alarm horn momentarily to test warning circuits.

**4** Lanyard Stop Switch - Refer to page 1 for explanation. The lanyard cord/clip, when used with the lanyard stop switch **MUST BE** connected to boat driver. Should driver be unable to reach steering wheel or remote control, the lanyard cord/clip will be pulled from lanyard stop switch and the engine will shut OFF. This lanyard stop switch **SHOULD NOT BE USED** as normal engine shut-off.

**IMPORTANT: The Lanyard Stop Switch can be repositioned to RUN with or without lanyard cord/clip so that engine can be restarted.**

**5** Engine can be restarted with or without lanyard cord/clip installed by simply pushing switch up to run position. If necessary push switch down with key to reinstall clip.

**6** Fast Idle Lever - Allows engine throttle advancement, without shifting gears, to assist engine starting.

**7** Throttle Friction Adjustment Knob - Adjusts control handle friction so that boat speed can be set and driver does not have to hold handle. Turn knob clockwise to increase friction. **DO NOT** thread knob all the way out.

**8** Tachometer Receptacle - Wiring harness connector for tachometer.

**9** Trim/Tilt Switch - trim outboard out (up) by pressing up on switch; trim outboard in (down) by pressing down on switch.

**10** Warning Horn Located in Remote Control Refer to "Operation" - "Warning Horn Operation" following.

## OPERATION MODELS WITH REMOTE CONTROL

### WARNING HORN OPERATION

This engine is equipped with a warning system to signal engine overheat and low oil level in the oil injection system.

The warning horn is located inside of side mount remote control. If boat is equipped with a panel or console remote control, the warning horn is incorporated behind the key switch in the key switch wiring harness.

Each time the key switch is turned from the "OFF" position to the "ON" position the warning horn will sound momentarily. This indicates that the warning system will function when the engine is running.

### ▲CAUTION

**If the warning horn fails to sound momentarily when the key switch is turned from the "OFF" position to the "ON" position or continually sounds, see an Authorized Dealer. DO NOT operate the engine.**

The warning system gives the following indications:

**MOMENTARY BEEP** (when key switch is turned on) - circuit test of warning system.

**STEADY BEEP** - Engine is overheated.

**INTERMITTENT BEEP** - Oil injection oil level low.



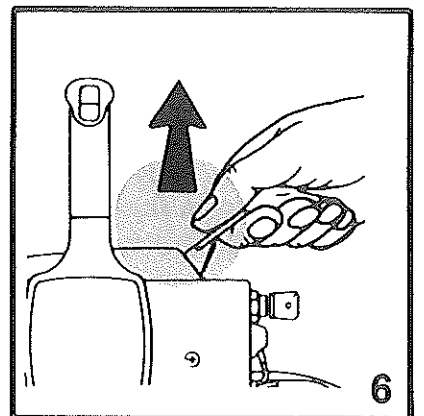
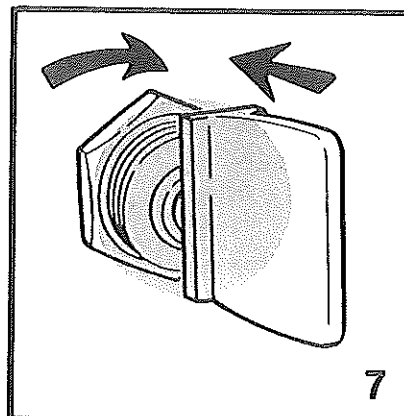
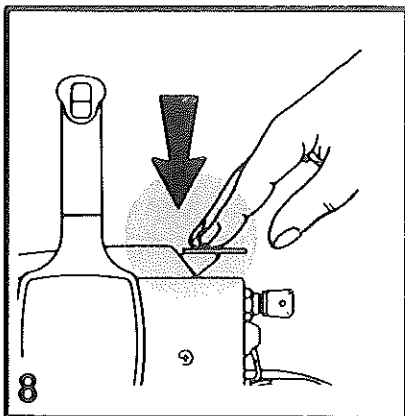
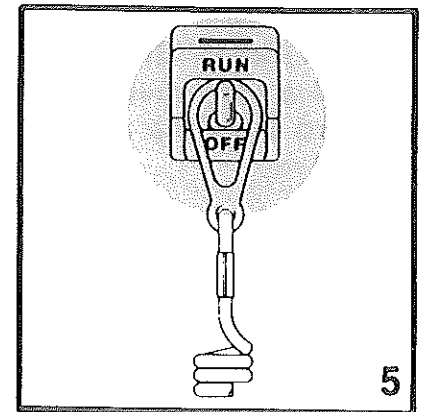
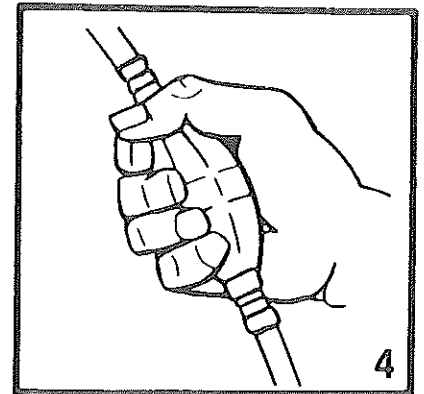
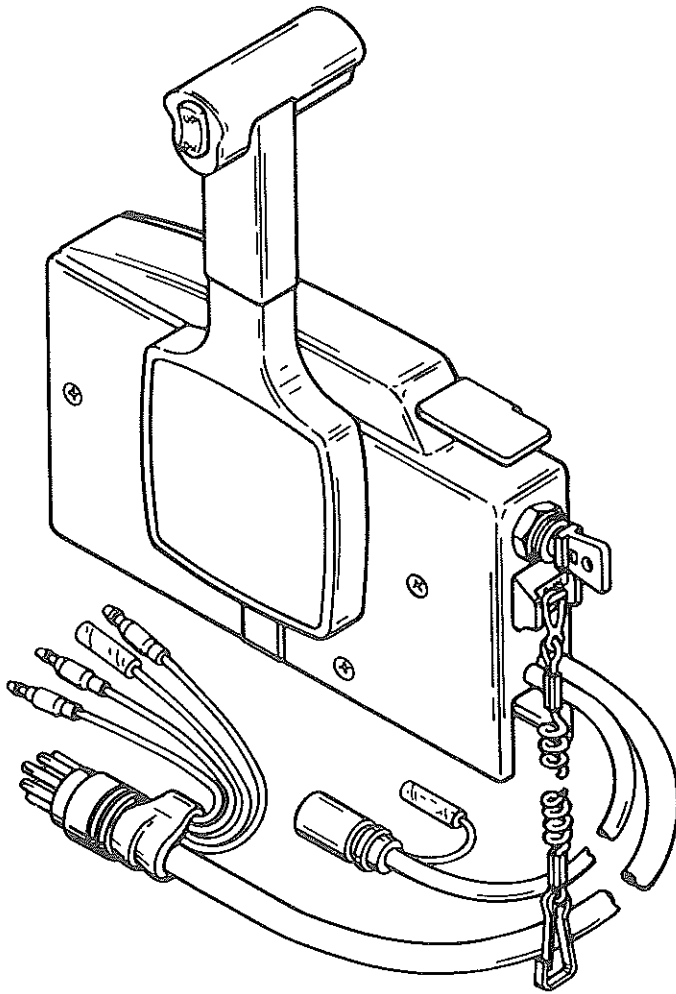
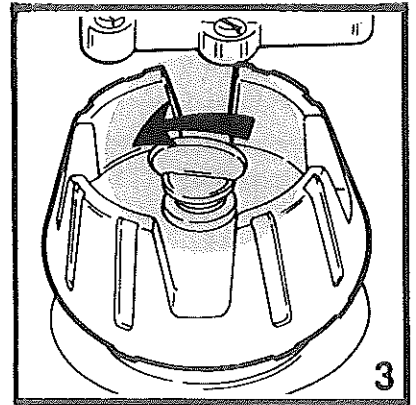
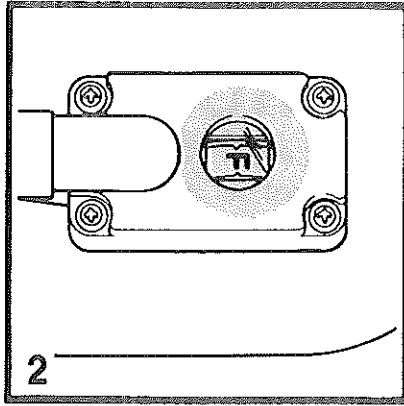
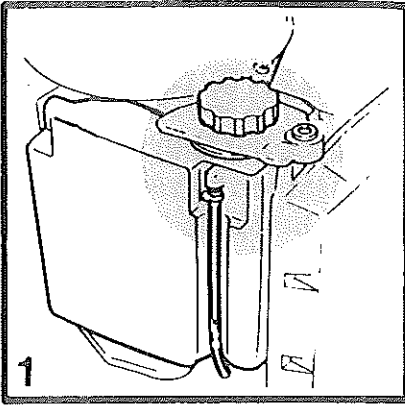

# OPERATION

## MODELS WITH REMOTE CONTROL (Continued)



### CAUTION

**OPERATOR and PASSENGERS SHOULD BE SEATED WHENEVER ATTEMPTING to START the ENGINE.**

Before attempting to start motor, **MAKE CERTAIN** that motor is shifted into **NEUTRAL** and that area around boat is clear (to get underway).



### CAUTION

This outboard is water cooled. **DO NOT** operate outboard with cooling water intake out-of-water or serious damage to outboard could result from overheating.

**IMPORTANT:** Remote control must be equipped with a starter "cut-out" switch -- remote control handle **MUST BE** in **NEUTRAL** position in order to operate the starter.

### BEFORE STARTING

Tilt outboard to vertical position.

- 1 Check oil level in oil injection system tank - add oil as necessary.
- 2 Check fuel tank for sufficient fuel and that tank is secure in boat.
- 3 Open air vent on fuel tank cap.
- 4 Squeeze fuel primer bulb until it is firm.
- 5 Place control handle in **NEUTRAL**. Check that lanyard stop switch is in **RUN** position.



### WARNING

The need for steering system/remote control inspection or service is indicated by increased effort or binding while turning the steering wheel, excessive free-play or unusual sounds. If any of these problems exist, contact your Dealer immediately. Use extreme care if operating boat before repairs are made.

Check remote control and steering operation.

Turn key from **OFF** to **ON** to test warning

circuit. The alarm horn should sound only momentarily. If it does not, contact an Authorized Dealer.



### CAUTION

**DO NOT** operate starter motor for longer than 30 seconds or starter motor may be damaged. Allow at least 2 minutes between starting attempts.

**IMPORTANT:** Starter circuit is protected by **SFE 20 AMP** fuse on right side of engine. If starter fails to operate, check for blown fuse. **BEFORE** replacing fuse, locate and correct cause of overload.

### STARTING COLD ENGINE

**6** Lift Fast Idle Lever to a point halfway between full up and full down position.

**IMPORTANT:** With Fast Idle Lever in up position, control handle **CANNOT** be moved into **FORWARD** or **REVERSE GEAR**.

**7** Turn key clockwise to **RUN** position and push in on key to activate enrichener. Hold key in the pushed in position for 4 to 6 seconds, then turn key clockwise past **RUN** position to **START**.

As soon as engine starts, allow key to return to **RUN** position and release enrichener. If engine falters, push in on key to actuate enrichener again.

**8** After warm-up, return Fast Idle Lever to full down position.



### WARNING

Be prepared to alter throttle setting when engine starts. **DO NOT** allow engine to exceed **2500 RPM** while in **NEUTRAL**.

### STARTING WARM ENGINE

Place control handle in **Neutral**. Turn key clockwise past **RUN** position to **START**.

As soon as engine starts, allow key to return to **RUN** position. If engine falters, push in on key to actuate enrichener.

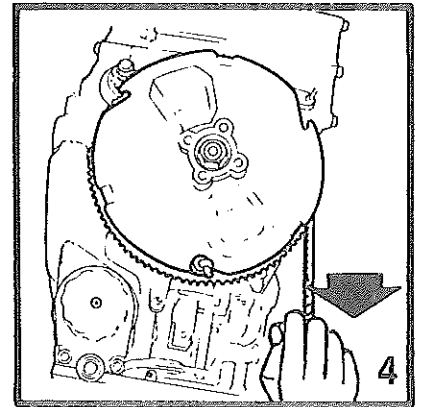
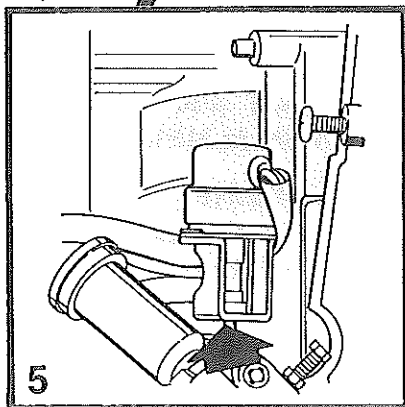
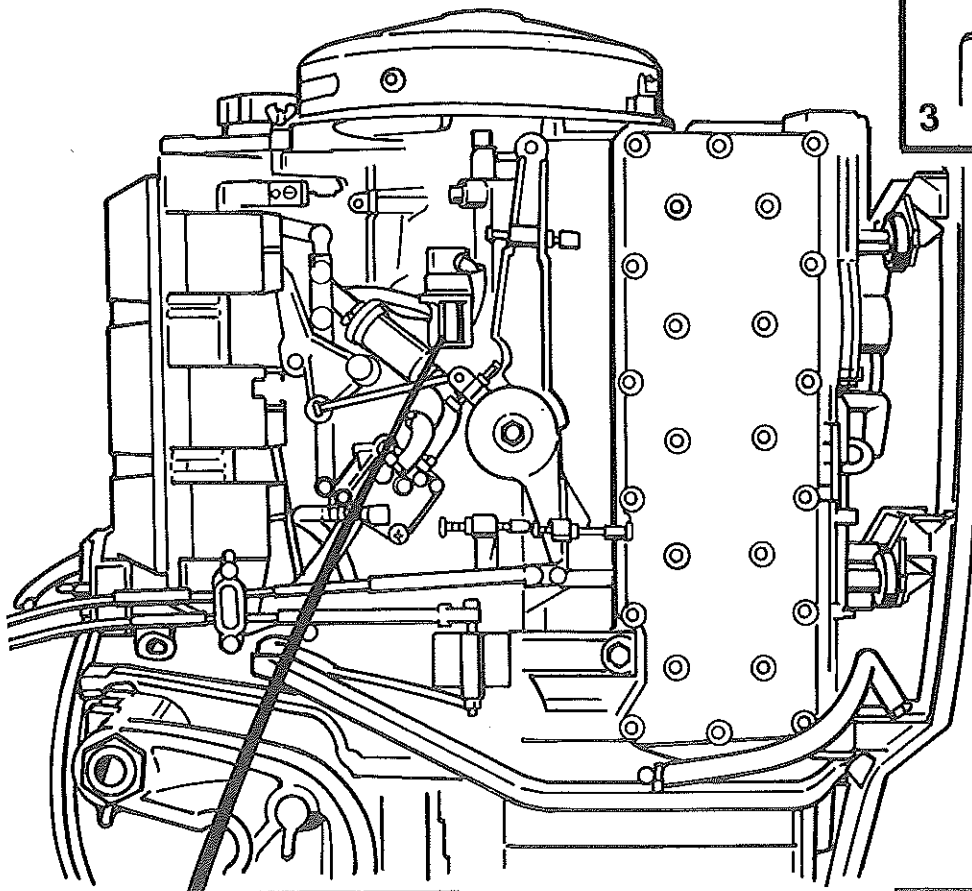
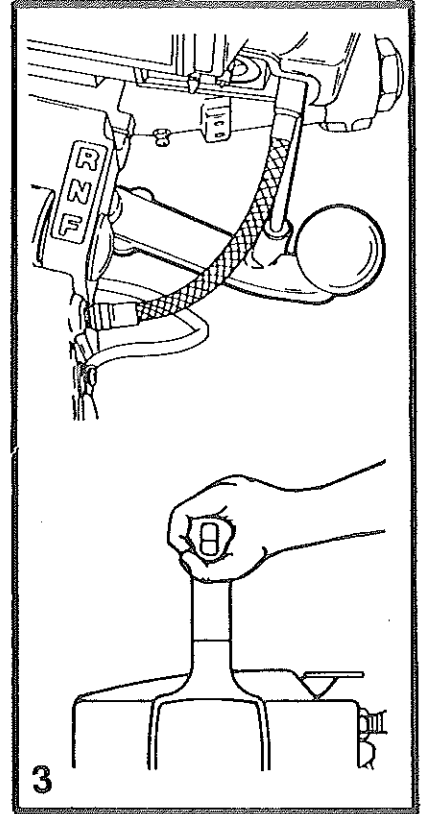
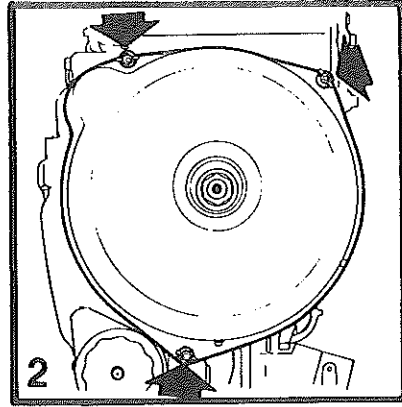
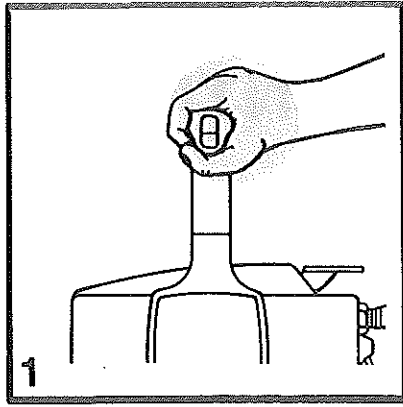

# OPERATION

## MODELS WITH REMOTE CONTROL

### (Continued)

NOTE: If engine fails to start, follow STARTING COLD ENGINE procedure.

Check for steady stream of water from water pump "Tell-Tale". If intermittent or no flow is observed, STOP ENGINE IMMEDIATELY. Check "Tell-Tale" stream often during motor operation.

#### ▲CAUTION

A continuous warning horn will sound if engine overheats. Stop engine immediately if alarm sounds. Locate and remedy cause of overheating before using motor.

#### THROTTLE/SHIFTING GEARS

1 Squeeze Neutral Lock Bar and push control handle forward to engage FORWARD GEAR. Pushing handle further forward increases engine speed.

#### ▲CAUTION

Exercise extreme care when operating in REVERSE GEAR. DO NOT operate engine at high speeds in REVERSE.

Squeeze Neutral Lock Bar and pull back on control handle to engage REVERSE GEAR.

#### STOPPING THE ENGINE

Shift to NEUTRAL and turn key counterclockwise to OFF position.

**IMPORTANT:** In an emergency the engine can be stopped at any speed, in or out of gear. For normal operation, idle engine and shift to NEUTRAL before turning key to OFF.

#### ▲WARNING

If motor will not be operated for a period of time, if it is to be removed from boat, or if it is to be tilted up, prevent spillage from carburetor throat and bowl and gum formations in the carburetor during storage as follows:

- Disconnect the fuel line.
- Allow engine to idle until it stops, indicating the carburetors have run dry.
- Turn electric start key to OFF.
- Disconnect positive (+) battery lead to prevent accidental starting or shorting.

## EMERGENCY OPERATION

#### ▲CAUTION

Battery leads must be connected to battery (even if battery is dead).

Remove cowl (refer to COWL REMOVAL AND INSTALLATION).

2 Remove 3 wing nuts from flywheel cover and lift cover off. Remove starter rope from pocket inside cowl.

3 Shift outboard or remote control into neutral.

#### ▲WARNING

When using emergency starter rope to start outboard, the start-in-gear protection provided by the remote control is inoperative. Make sure to shift remote control handle into neutral before starting outboard to prevent outboard from starting in gear. Sudden unexpected acceleration can cause serious injury or death.

4 Engage knot of starter rope in one of the flywheel plate notches and wind rope clockwise around flywheel.

Turn key switch to RUN.

5 If engine is cold, push button on fuel enrichener. Wait 4 to 6 seconds. Avoid using enrichener if engine is warm.

Observe preliminary outboard starting steps as outlined in OPERATION procedures and pull rope to start engine. Repeat, if engine has not started.

#### ▲WARNING

Care must be taken when using emergency starting procedure. DO NOT attempt to replace flywheel cover or cowl after engine has started. Stay clear of flywheel. DO NOT WEAR loose clothing when operating under these conditions.

# POWER TRIM



## WARNING

Keep a tight grip on the steering wheel/tiller handle, especially when changing speed or trimming boat and motor. Trim motor after reaching cruising speed. While trimming, steering loads will vary and will pull in one direction until a balanced condition has been attained. If the outboard is trimmed past the balanced steering condition, the steering wheel/tiller handle will then have a tendency to pull in the opposite direction. Excessive trimming past the balanced steering position will result in increased steering loads and, in most boating applications, a decrease in performance.

**IMPORTANT:** Power Trim electrical circuit is protected by a 20 AMP fuse mounted under the cowl. If the Power Trim fails, check for a blown fuse. **BEFORE** replacing fuse, locate and correct the cause of the overload.

## OPERATION

The control handle/control panel is equipped with a trim/tilt switch which tilts the motor out (up) and in (down). Refer to **REMOTE CONTROL/OUTBOARD MOTOR CONTROL TILLER HANDLE MODELS**.



## CAUTION

If motor will be operated in shallow water with motor trimmed beyond 20° trim limit follow these precautions:

- **DO NOT** operate engine above 2000 RPM. When motor is trimmed beyond 20° trim limit the swivel bracket will not have side support.

- Check that water level is above water intake ports to avoid overheating or water pump impeller damage.

Motor can be trimmed beyond 20° limit for launching, trailering, shallow water operation, etc., if engine speed does not exceed 2000 RPM.

To trim/tilt motor out (up) - push up on switch.

To trim/tilt motor in (down) - push down on switch.

To trim/tilt motor beyond 20° limit - decrease engine speed to less than 2000 RPM and push up on switch.

## Trimming Motor Out (Up) Will:

- Lift bow of boat.
- Generally increase top speed.
- Increase left hand steering torque (with transom height less than 23").
- Increase clearance over submerged objects.
- In excess, cause porpoising and/or ventilation.
- Cause overheating if trimmed out (up) beyond water pickup.



## WARNING

Some high speed hulls may become unstable if motor is trimmed too far out (up). To correct such instability, reduce power **GRADUALLY** and trim motor in (down) before resuming high speed. Cutting power too quickly may momentarily create even greater instability.

# POWER TRIM

## (Continued)

### Trimming Motor In (Down) Will:

- Result in quicker planing off, especially with heavy loads.
- Generally improve ride in choppy water.
- Increase right hand steering torque.
- Improve acceleration at planing speeds.
- In excess, cause boat to veer to left or right (bow steer).



### WARNING

Unsafe steering conditions may result at high speeds with the motor trimmed all the way in (down). Test your boat for changes in handling whenever trim angle is changed.

### CHECKING OIL LEVEL

Check power trim oil level periodically as follows:



### CAUTION

DO NOT open fill screw while motor is in (down) position. The reservoir is under pressure and oil may blow out of fill hole.

A. Tilt motor to full out (up) position.

B. Remove fill cap from trim pump reservoir.

C. Fluid level should be visible in fill hole; if not, add Quicksilver Power Trim & Steering Fluid or; Automotive Transmission Fluid (ATF) Type F, FA or Dexron II.

D. Reinstall fill cap.

### TILTING MOTOR MANUALLY

Rotate release valve control knob (see MOTOR INSTALLATION) full to the left (counterclockwise) to allow motor to be tilted either up or down manually.



### CAUTION

Before operating motor, manual release valve must be turned fully clockwise to allow reverse lock to operate.

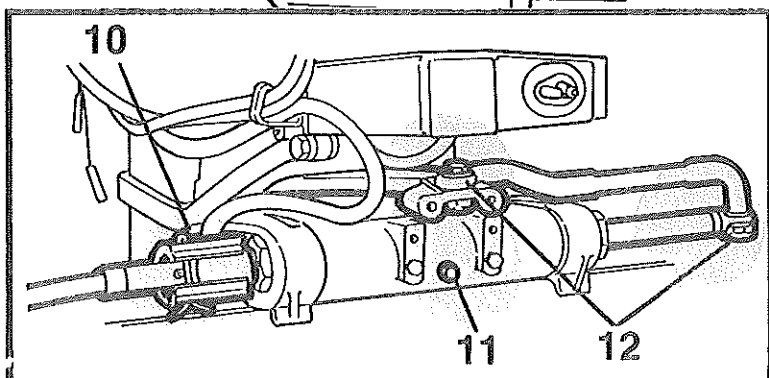
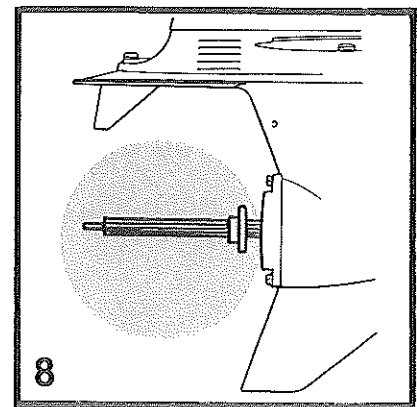
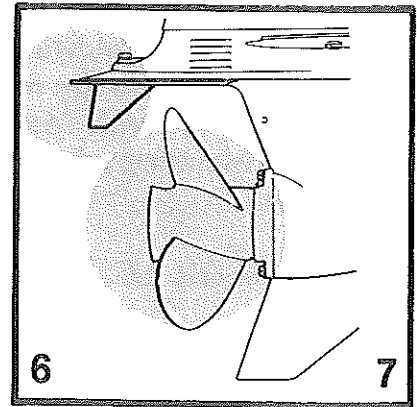
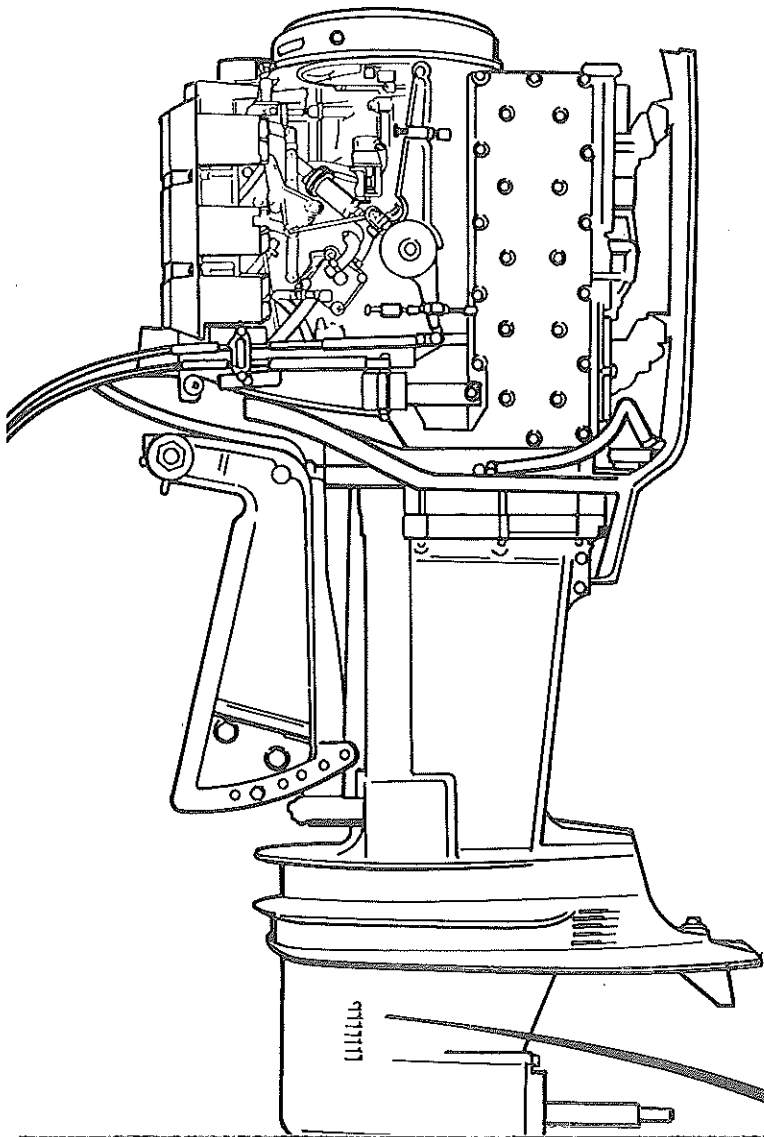
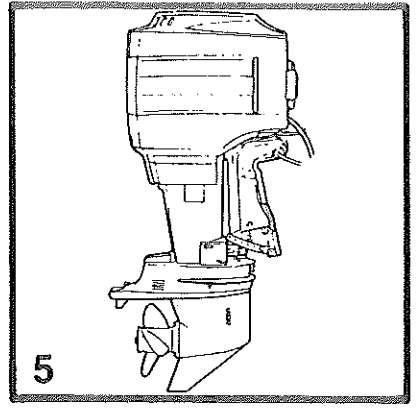
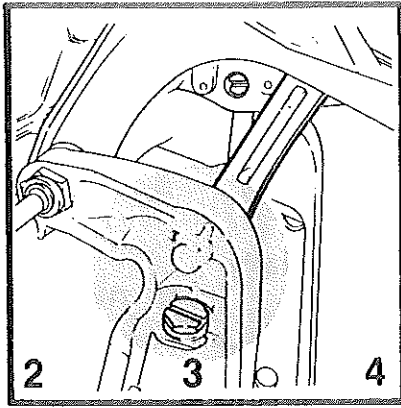
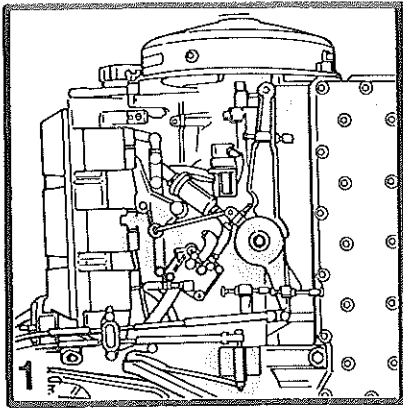

# LUBRICATION/ MAINTENANCE GUIDE

ITEM	DESCRIPTION	TYPE OF LUBRICANT OR MAINTENANCE	FRESH WATER FREQUENCY	SALT WATER FREQUENCY
1	Throttle/Shift Linkage (All Pivot Points)	A	Every 60 days	Every 30 days
2	Tilt Lock Lever	A	Every 60 days	Every 30 days
3	Power Trim Pump Oil Level	C	Every 100 hours or once a season	Every 100 hours or once a season
4	Swivel Pin	A	Every 60 days	Every 30 days
5	Motor Exterior	Clean and Inspect	Once a season	Occasionally
6	Trim Tab	Inspect - Replace if Necessary	Every 30 days	Every 30 days
7	Propeller	Inspect and Tighten Prop Nut	Every 50 hours	Every 50 hours
8	Propeller Shaft	A	Once a season	Every 60 days
9	Gear Housing	B	Check and fill after 1st 10 days, then every 30 days	Check and fill after 1st 10 days, then every 30 days
			Drain and Refill after 1st 25 hours, then after every 100 hours, or once a year before storing	Drain and Refill after 1st 25 hours, then after every 100 hours, or once a year before storing
10	Ride-Guide Steering Cable	A	Every 60 days	Every 30 days
11	Tilt Tube	A	Every 60 days	Every 30 days
12	Steering Link Rod Pivot Points	D	Every 60 days	Every 30 days
	All Bolts, Fasteners, etc.	Check Tightness	Every 100 hours	Every 100 hours

### Type of Lubricants

A = Quicksilver 2-4-C Marine Lubricant

B = Quicksilver Gear Lube

C = Quicksilver Power Trim & Steering Fluid or; Automotive Transmission Fluid (ATF) Type F, FA or Dexron II

D = SAE 30W Motor Oil



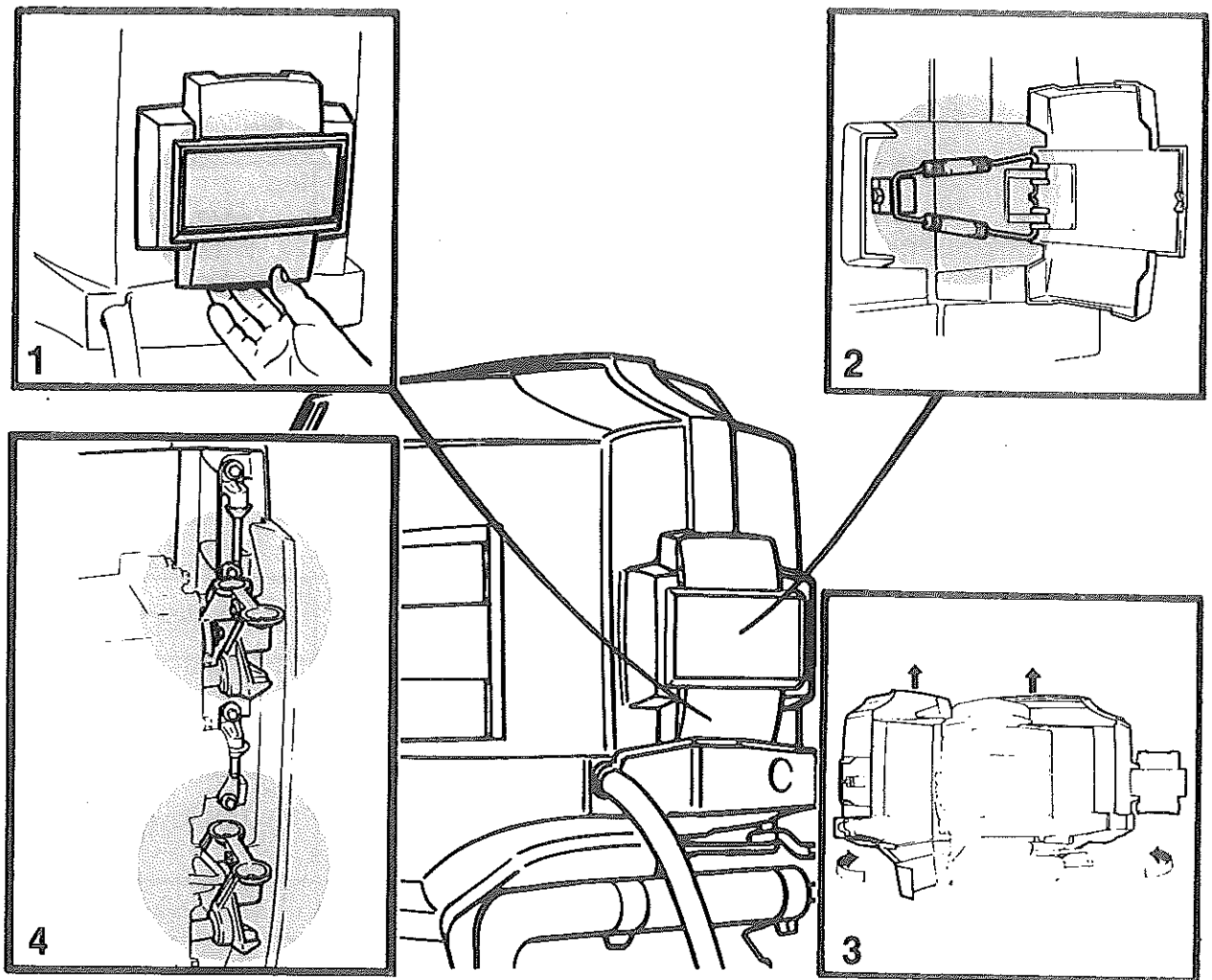

## COWL REMOVAL AND INSTALLATION



### WARNING

**DO NOT ATTEMPT TO REMOVE OR INSTALL COWL WHILE ENGINE IS RUNNING.**

### REMOVAL

- 1** Pull outward on front cowl cover and swing to right.
- 2** Unhook spring latch from retainer on cowl.

- 3** Push each side on cowl outward and lift cowl up to remove.

### INSTALLATION

Position cowl around motor.

- 4** Insert cowl pins into pin sockets mounted on engine.
- Pull cowl sides together at front of motor and hook spring latch.
- Close front cowl.

# GEAR HOUSING LUBRICATION



## CAUTION

Have gear housing checked by your local service dealer if any of the following are found:

- Water drains from filler hole.
- Metal particles are present on magnetic fill plug.

**NOTE:** Presence of a small amount of fine metal particles (resembling powder) indicates normal wear.

- Lubricant appears milky brown.
- Large amounts of lubricant must be added to fill gear housing.

**IMPORTANT: DO NOT use automotive lubricant in gear housing. Use only Quick-silver Gear Lube.**

## CHECKING LUBRICANT LEVEL

**IMPORTANT: Inspect fill and vent plug washers for damage. Use new washers as needed.**

**1** Remove lubricant fill plug and washer. Note amount of metal particles on magnetic fill plug. Refer to caution, preceding.

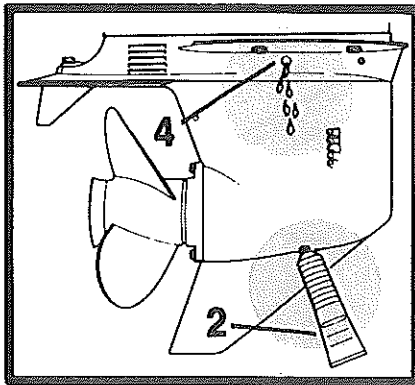

**2** Insert lubricant tube in fill hole.

**3** Remove both vent plugs with washers.

**IMPORTANT: Never add lubricant to gear housing without first removing both vent plugs, as trapped air will prevent housing from being filled. Fill gear housing only when motor is in operating position.**

**4** Add lubricant to gear housing until excess starts to flow from one (first) vent hole. If this requires more than 2-3 fl. oz. (60-90ml) of lubricant, refer motor to authorized dealer. Install vent plug and washer for this vent hole only.

Continue to add lubricant until excess starts to flow from remaining vent hole.

Install remaining vent plug and washer.

Remove lubricant tube and install cleaned magnetic fill plug and washer.

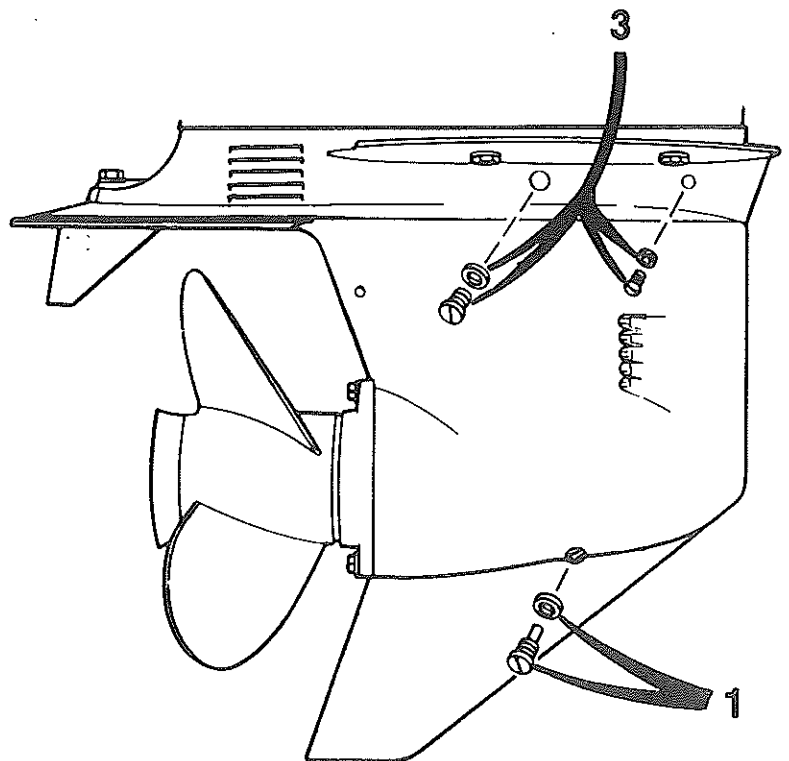

1153-H

# GEAR HOUSING LUBRICATION

## (Continued)

### DRAINING AND REFILLING GEAR HOUSING LUBRICANT

Tilt motor so that, lubricant in gear housing will drain toward front of housing, out fill hole and into clean container.

**IMPORTANT: Inspect fill and vent plug washers for damage. Use new washers as needed.**

**1** Remove lubricant fill plug and washer. Note amount of metal particles on magnetic fill plug. Refer to caution, preceding.

**2** Remove both vent plugs with washers and allow sufficient time for all lubricant to drain.

**IMPORTANT: Never add lubricant to gear housing without first removing both vent plug, as trapped air will prevent housing**

**from being filled. Fill gear housing only when motor is in operating position.**

**3** With motor in operating position, insert lubricant tube into fill hole.

**4** Fill gear housing with lubricant, until excess starts to flow from one (first) vent hole (approximately 22.5 fl. oz. [666ml] of Quicksilver Gear Lube). Install vent plug and washer for this vent hole only.

Continue to add lubricant until excess starts to flow from remaining vent hole.

Install remaining vent plug and washer.

Remove lubricant tube and install cleaned magnetic fill plug and washer.

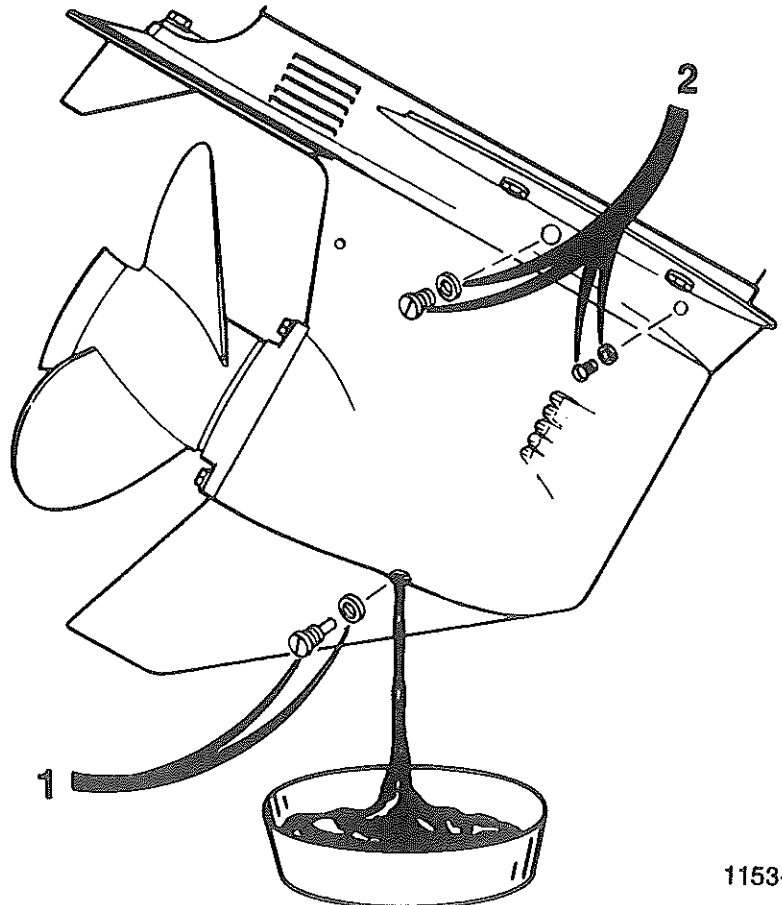
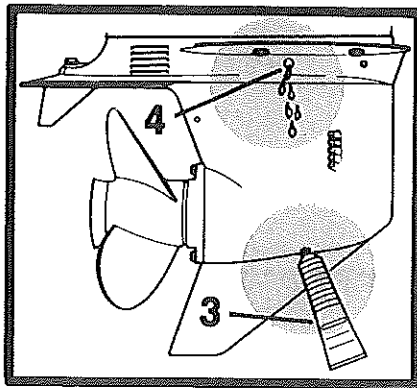

# FLUSHING MOTOR COOLING SYSTEM

## CAUTION

When flushing, be certain the area around propeller is clear, and no one is standing nearby. To avoid possible injury, remove the propeller.

To prevent silt and/or salt buildup in cooling system, flush with fresh water periodically.

**1** Install Quicksilver Flushing Attachment (or equivalent) on the gear housing FRONT side, over water intake openings.

**2** Connect hose between flushing attachment and water tap.

**3** With motor in normal operating position, open water tap and adjust flow so that some water leaks from around cups.

**4** Check that water is running from "Tell-Tale". Shift motor to NEUTRAL and start. Increase engine speed to approximately 1500 to 2000 RPM.

## CAUTION

**DO NOT** over-rev. Run at slower speeds only.

With engine running at IDLE speed, continue flushing until water becomes clear (3 to 5 minutes for salt water units).

**5** Stop engine, turn off water and remove flushing attachment.

**IMPORTANT:** Keep motor in upright position until all water has drained out. Water left trapped in motor could cause engine damage.

**6** Clean motor surfaces and wipe with Quicksilver Corrosion Guard to protect finish. Refer to LUBRICATION/MAINTENANCE GUIDE.

**NOTE:** Keep motor in normal operating position when moored, otherwise zinc trim tab cannot act as a galvanic corrosion inhibitor.

When storing motor, be sure to disconnect positive (+) battery terminal.

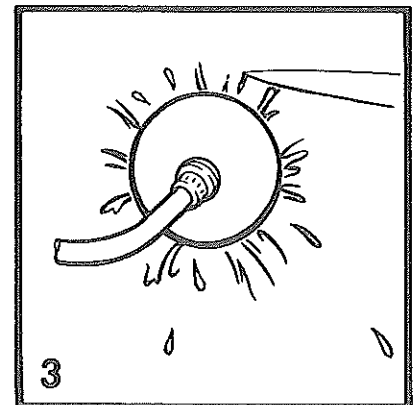
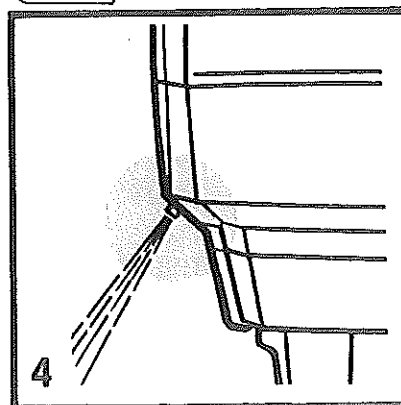
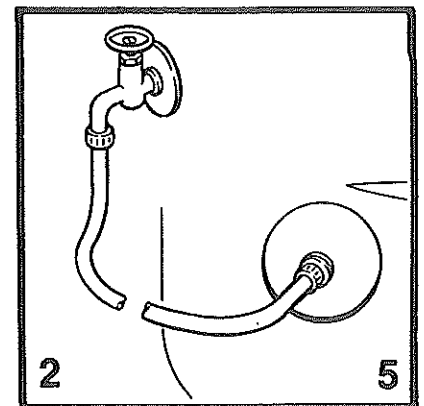
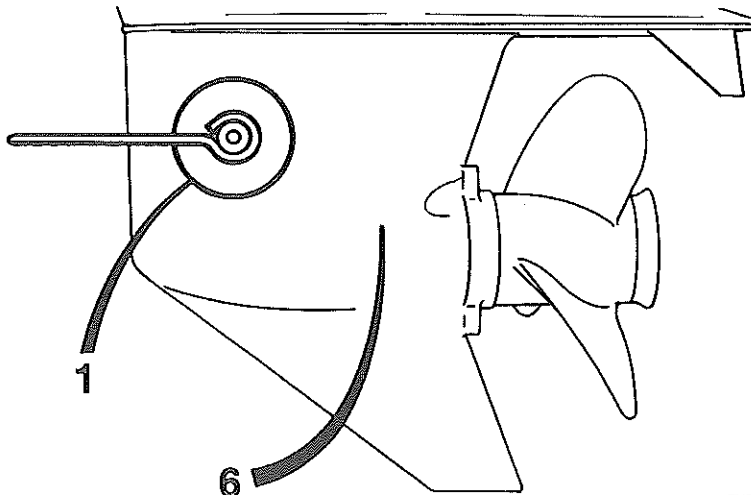

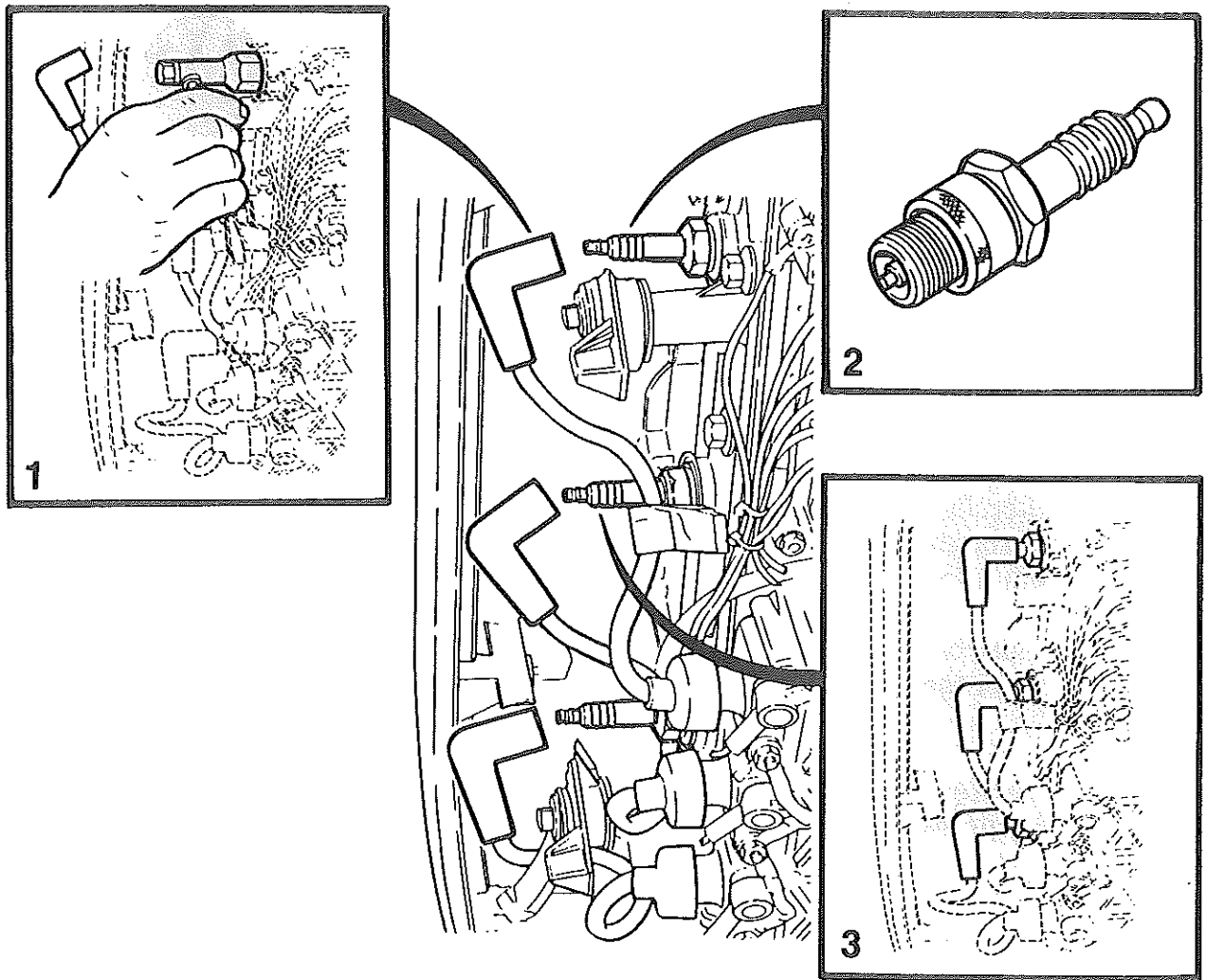

## IGNITION MAINTENANCE



### CAUTION

**DO NOT touch or disconnect any ignition system parts while engine is running, as high voltage is present.**

If electrical/ignition system is not operating, **DO NOT** attempt to repair it yourself. Refer to your authorized service facility.

### SPARK PLUGS

Periodic inspection, cleaning and/or replacement of spark plugs will enhance motor performance. Always replace spark plugs with those specified in SPECIFICATIONS.

Replace spark plugs as follows:

Remove cowl. (Refer to COWL REMOVAL AND INSTALLATION.)

**1** Disconnect spark plug leads and use 13/16" wrench, to remove spark plugs.

**2** Check that gaskets are in place and install new plugs.

Thread spark plugs in by hand until fingertight. Use wrench to tighten an additional 1/4 turn. **DO NOT OVER-TIGHTEN.**

**3** Reconnect spark plug leads to correct plugs.

Inspect spark plug leads for damage - replace as necessary.

# CARBURETOR ADJUSTMENT

The carburetors have been calibrated and pre-set at factory to provide best performance under normal conditions. However, extreme changes in weather and/or elevation may necessitate further carburetor adjustments.

**IMPORTANT:** To maintain peak motor performance when operating at **HIGHER ELEVATIONS**, it will be necessary to install a **LEANER** fixed high speed jet. (See your authorized service facility.)

## LOW SPEED MIXTURE

**IMPORTANT:** Boat/Outboard combination should be lake-launched before attempting to make engine idle mixture adjustments.

1 Pre-set low speed mixture screws as follows:

A. Turn idle mixture screw clockwise until screw is lightly seated.



### CAUTION

Continuing to tighten idle mixture screw after it has lightly seated may result in damage to screw and its seat.

B. Back-out screw 1-1/2 turns counterclockwise.

Start engine and allow to idle until engine warms up - approximately five minutes.

With engine at IDLE, shift outboard into FORWARD GEAR.

Slowly turn idle mixture screw clockwise (leaner). Engine RPM will increase until too lean a fuel mixture is obtained at which point engine will misfire and RPM decrease.

When too lean a mixture is achieved, turn idle mixture screw counterclockwise (richer) 1/2 turn.

With all carburetor idle mixture screws set at 1/2 turn out from lean idle point, engine should be accelerated quickly to wide-open throttle.

If engine hesitate during acceleration; idle mixture screw should be turned counterclockwise (richer) 1/4 turn. Repeat acceleration test and readjust idle mixture screw if necessary.

NOTE: Idle mixture screws which are set too lean will cause hard starting after engine has warmed up.

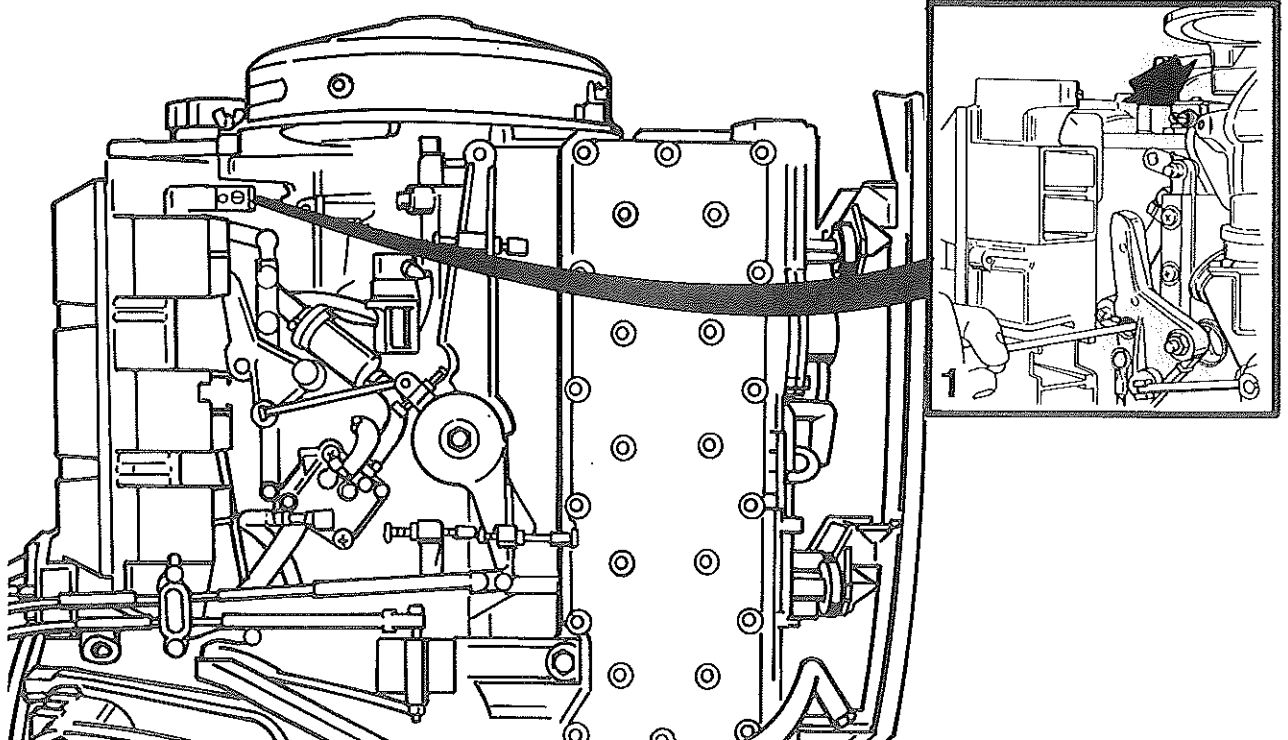

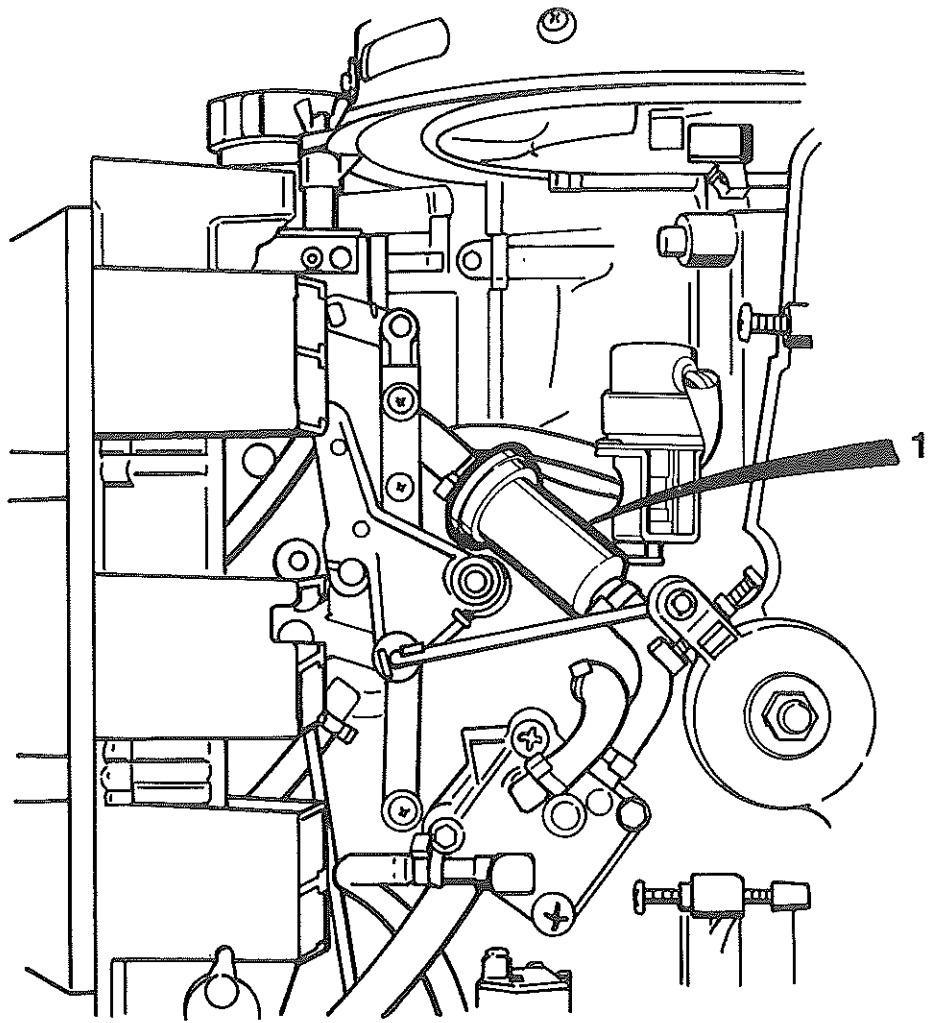

# CLEANING FUEL FILTERS



## WARNING

Be careful when cleaning fuel filter elements; gasoline is extremely flammable and highly explosive under certain conditions. Always stop the engine and **DO NOT** smoke or allow open flames in the area while cleaning fuel filter elements.

## 1 ENGINE FUEL FILTER

If engine fuel filter appears to be contaminated, remove and replace.

Prime fuel system and check for fuel leaks after replacing filter.



# INSPECTION AND MAINTENANCE

Inspect your motor often, and at regular intervals, to help maintain its top operating performance, and correct potential problems before they occur. The entire motor should be checked carefully, including all accessible engine parts.

Check for loose, damaged or missing parts; tighten or replace as required.

Lubricate and check gear housing oil level per LUBRICATION/MAINTENANCE GUIDE.

Service spark plugs. Check plug leads and electrical leads for damage.

Inspect fuel lines for damage. Service fuel filters.

Remove and inspect propeller. If badly nicked, bent or cracked, refer to Authorized Service Facilities. (Refer to PROPELLER - INSTALLATION.)

Repair nicks and corrosion damage on finish. Use Quicksilver spray paints - see

your Dealer.

Inspect trim tab. Replace if 50% of tab has been eroded away.

**IMPORTANT: DO NOT** apply paint or protective coatings to trim tab.

Check that remote control harness is connected and control is correctly adjusted.

## SPEED PICKUP MAINTENANCE

If water pickup is clogged, the speedometer will not operate.

Clean with a piece of wire or by blowing air through pickup. Before blowing out with air, disconnect tubing from speedometer.

To prevent freezing, drain system of all water before storage.

Remove tubing from speedometer fitting and blow through tubing to remove water.